

Transverse Coherence of a Vacuum Ultraviolet Free Electron Laser

Rasmus Ischebeck

November 19, 2003



Universität Hamburg



Transverse Coherence of a VUV Free Electron Laser

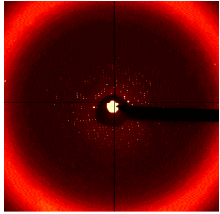

Introduction

- Relevance of Coherence
- Definition and Measurements

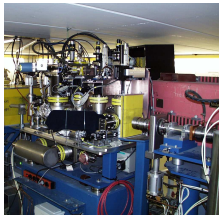

Measurements at the TTF FEL

- Challenges for the Measurements
- Experimental Setup

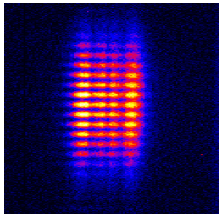

Results

- Coherence as a function of the slit separation
- Development along the undulator

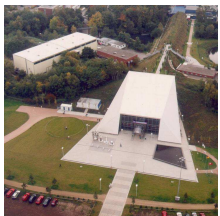

Outlook

- Phase 2 of the TTF FEL

Transverse Coherence of a VUV Free Electron Laser

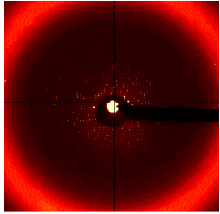

Introduction

- Relevance of Coherence
- Definition and Measurements



Measurements at the TTF FEL

- Challenges for the Measurements
- Experimental Setup

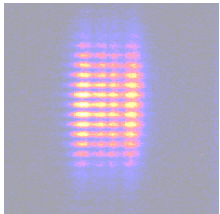

Results

- Coherence as a function of the slit separation
- Development along the undulator

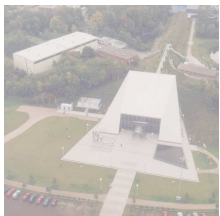

Outlook

- Phase 2 of the TTF FEL

Relevance of Coherence for Crystallography

- Diffraction pattern of a crystal \rightsquigarrow Structure of the molecule here: Ribosome

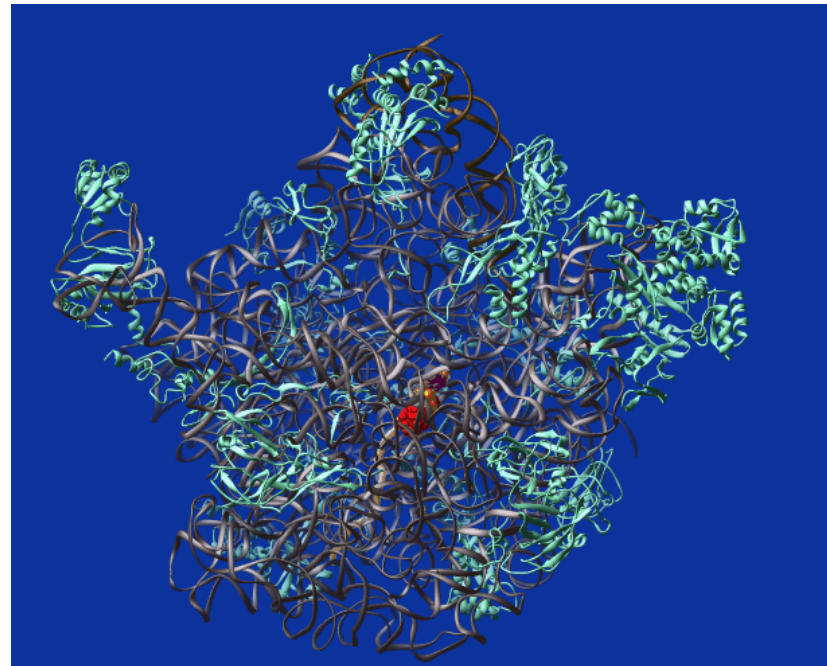
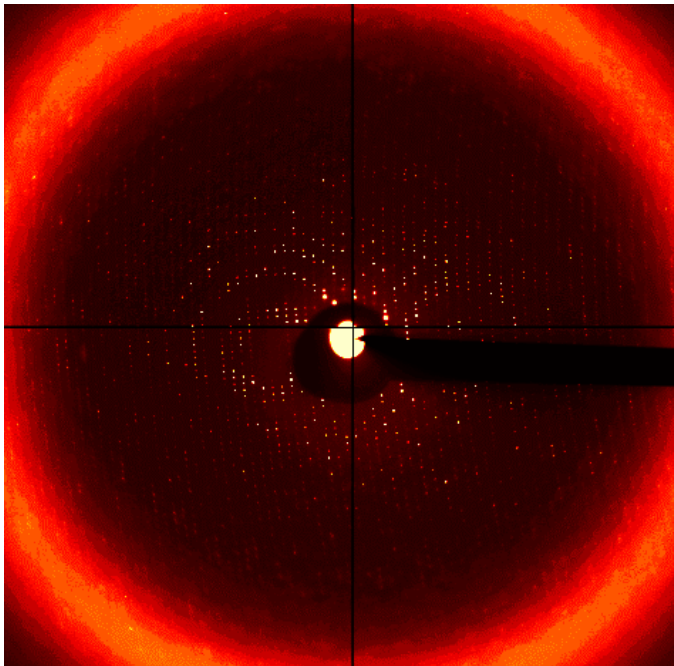

Pictures: Jörg Harms, Arbeitsgruppe für Ribosomenstruktur, Max-Planck-Gesellschaft

- Problem: Phase of the diffraction pattern is unknown

Rasmus Ischebeck, Transverse Coherence of a VUV Free Electron Laser

Relevance of Coherence

Diffraction Pattern of a Duck

- A (two-dimensional) duck

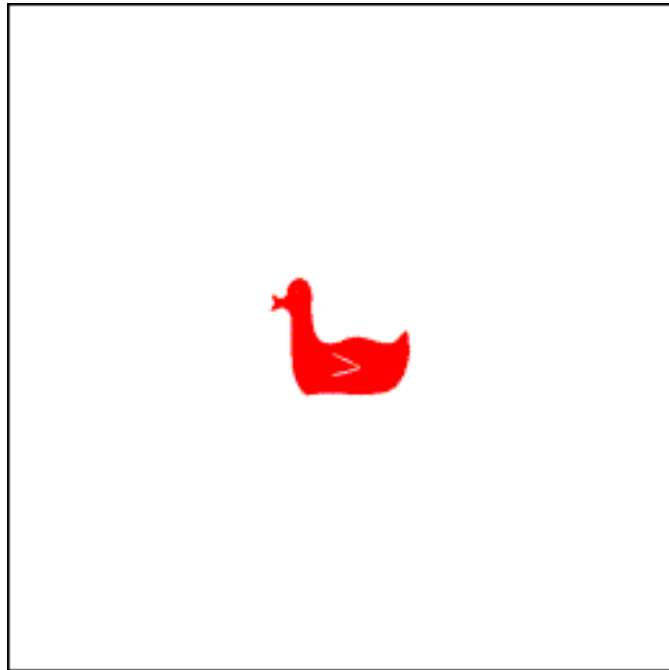

... creates this diffraction pattern
(the colors encode the phase)

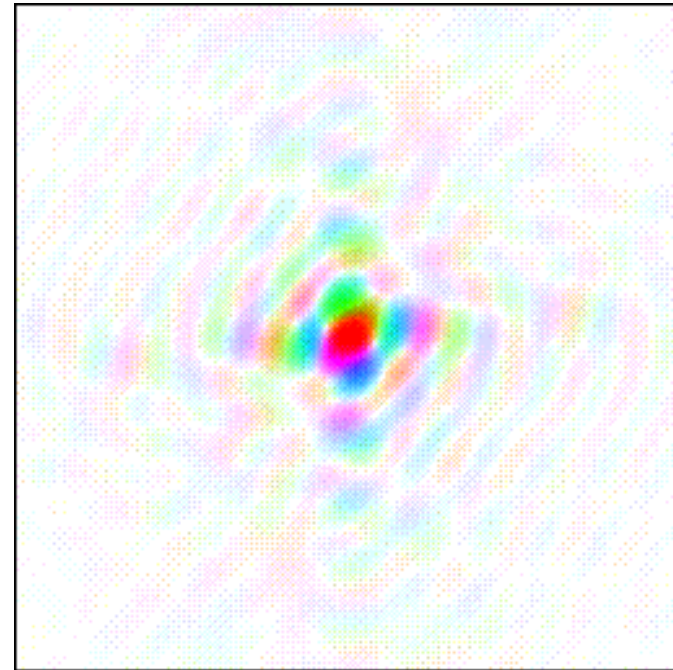

Images by Kevin Cowtan, Structural Biology Laboratory, University of York

Rasmus Ischebeck, Transverse Coherence of a VUV Free Electron Laser

Relevance of Coherence

Diffraction Pattern of a Cat

- A Cat

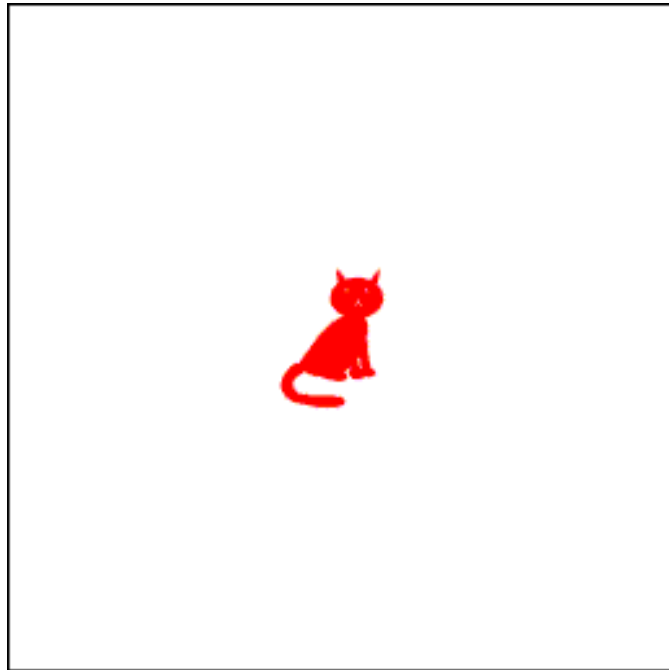

... and its Diffraction Pattern

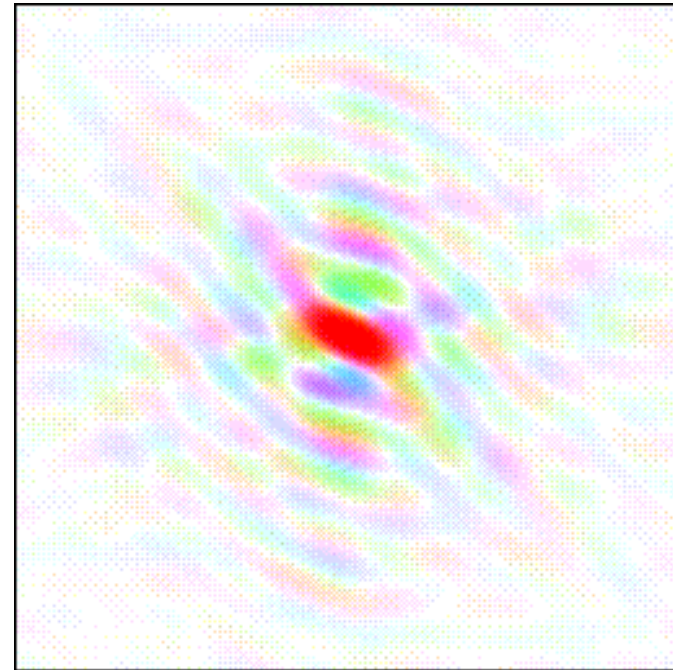

Images by Kevin Cowtan, Structural Biology Laboratory, University of York

Rasmus Ischebeck, Transverse Coherence of a VUV Free Electron Laser

Relevance of Coherence Reconstruction

- Combine the amplitude of the diffraction pattern of the cat
- and the phase of the diffraction pattern of the duck

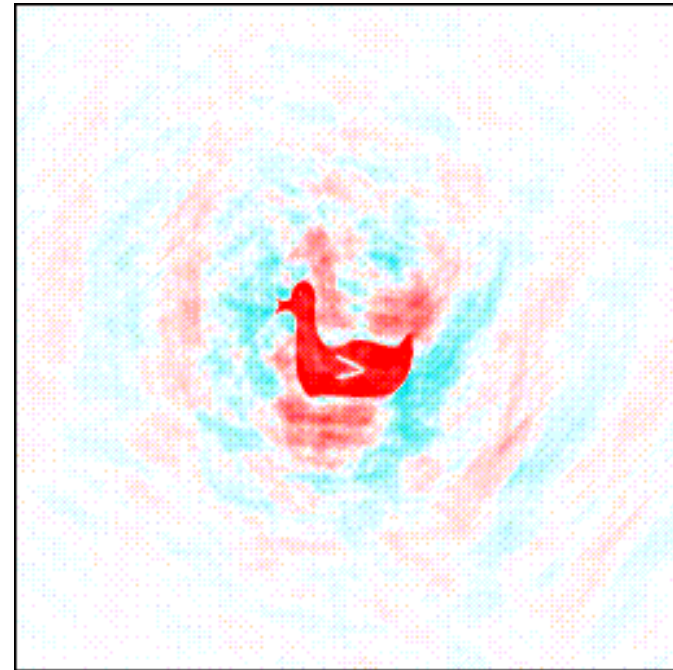
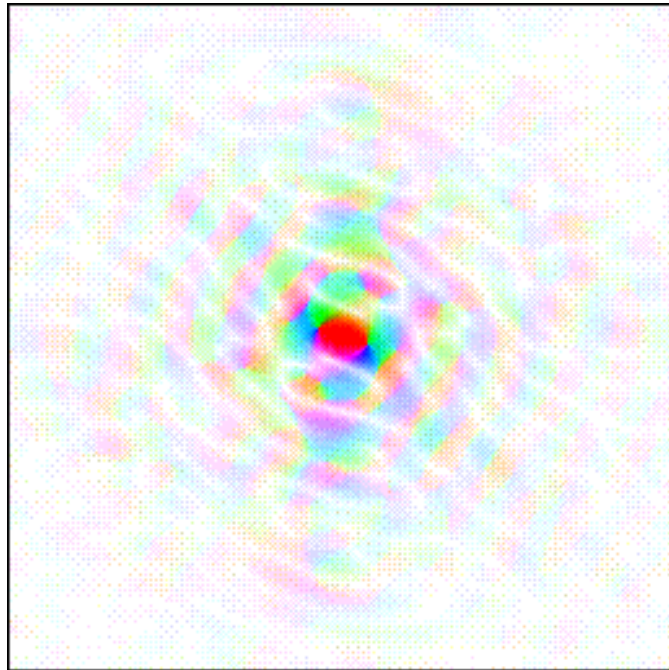

The result: a duck!

Images by Kevin Cowtan, Structural Biology Laboratory, University of York
Rasmus Ischebeck, Transverse Coherence of a VUV Free Electron Laser

Relevance of Coherence

Reconstruction

- Of course, one can also do the opposite trick:
- combine the amplitude of the duck and the phase of the cat

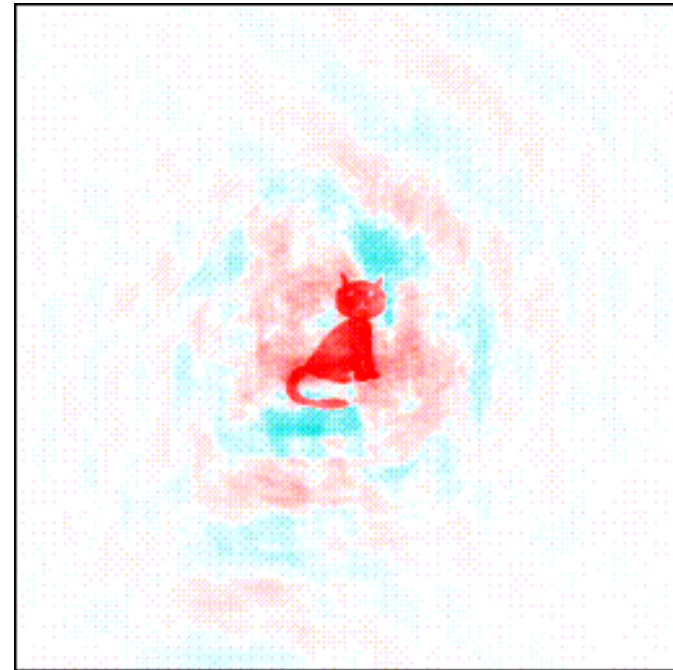
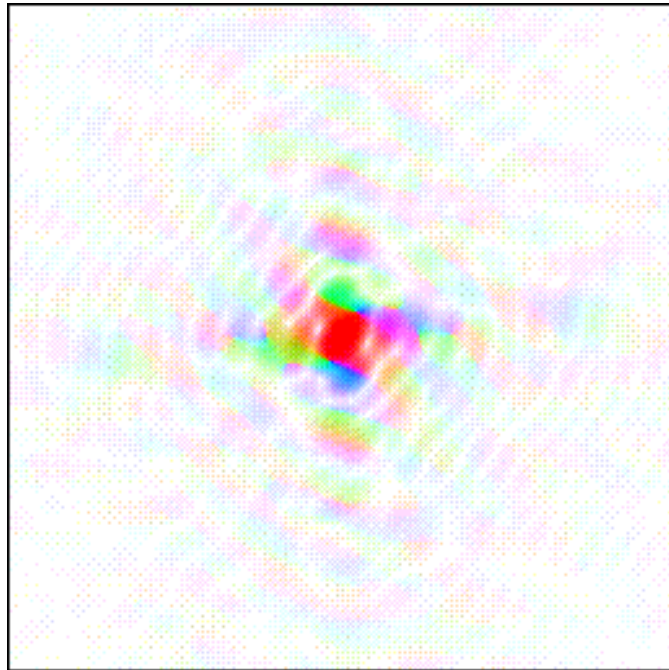

This is the famous **Phase Problem**

Images by Kevin Cowtan, Structural Biology Laboratory, University of York
Rasmus Ischebeck, Transverse Coherence of a VUV Free Electron Laser

Phase Problem

A Possible Solution: Holography

- Record the interference between object beam and reference beam

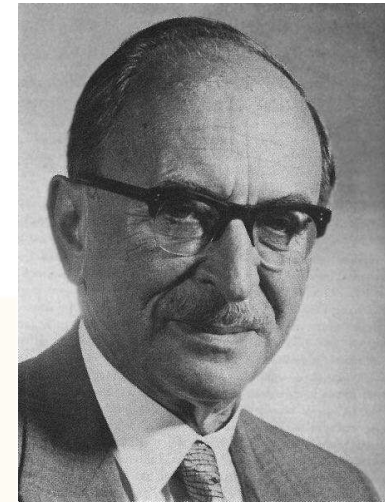
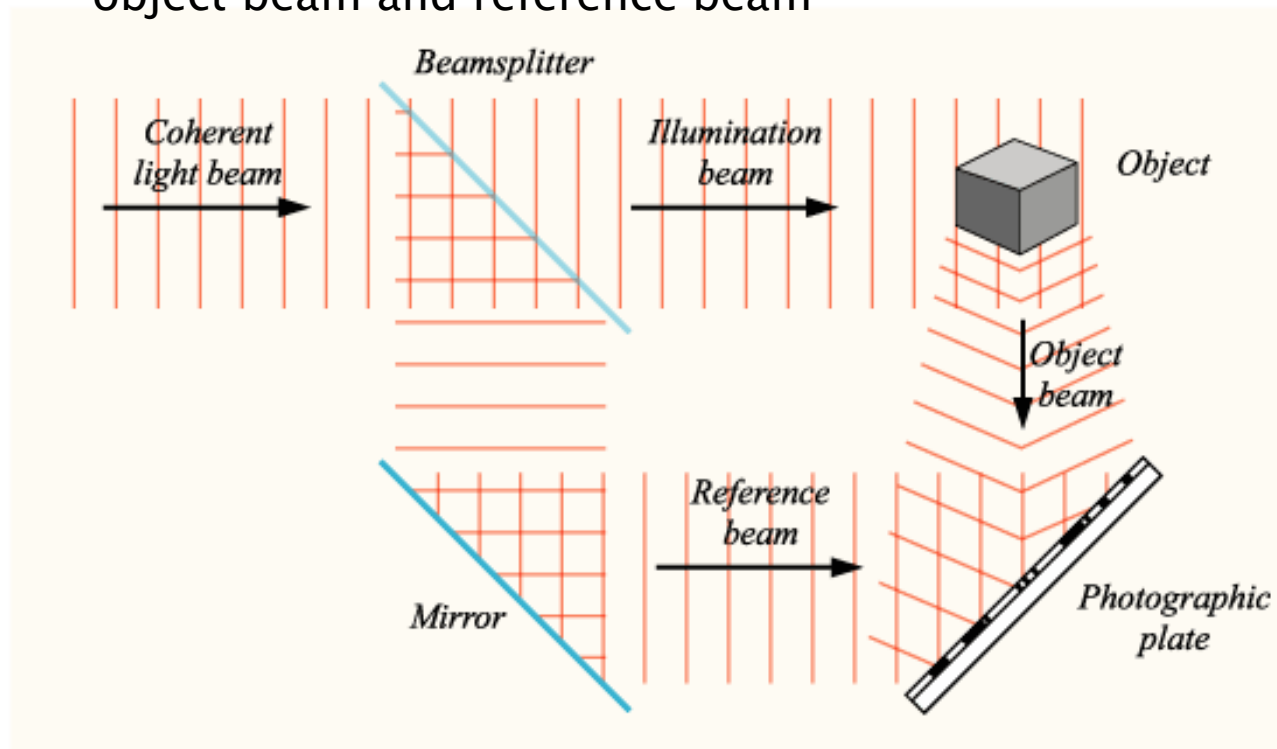

Dennis Gabor

- Necessary prerequisite: coherence of the incoming wave

Definition of Coherence Properties

- Electromagnetic wave: representation of a wave in z direction in the Slowly Varying Amplitude (SVA) approximation

$$\vec{E}(\vec{r}, t) = \text{Re} \left[\tilde{E}(\vec{r}, t) \exp \left(i(\omega t - \vec{k} \cdot \vec{r}) \right) \right] \vec{u}_x$$

- Correlation function

$$\tilde{\Gamma}(\vec{r}, \vec{r}') = \left\langle \tilde{E}(\vec{r}, t) \cdot \tilde{E}^*(\vec{r}', t) \right\rangle_t$$

$$\tilde{\gamma}(\vec{r} - \vec{r}') = \frac{\tilde{\Gamma}(\vec{r}, \vec{r}')}{\tilde{\Gamma}(\vec{r}, \vec{r})}$$

- Coherence function

$$\mathcal{C}(\Delta\vec{r}) = |\tilde{\gamma}(\vec{r} - \vec{r}')|$$

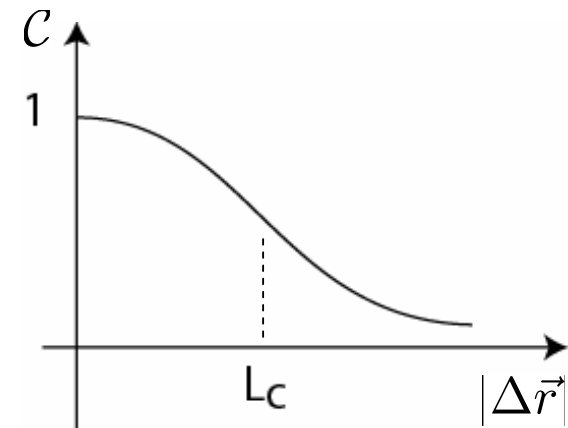

Coherence of Free Electron Lasers

- Decomposition of the radiation in its transverse modes

$$\tilde{E}(r, \vartheta, z) = \sum_{n,m} C_{nm}(z) \tilde{A}_{nm}(r, \vartheta)$$

- Development of the modes in the undulator

$$C_{nm}(z) = \exp\left(\frac{\Lambda_{nm}}{2} z\right)$$

- TEM modes (transverse electric and magnetic field)

- Cross section of the first Gauß-Laguerre modes:

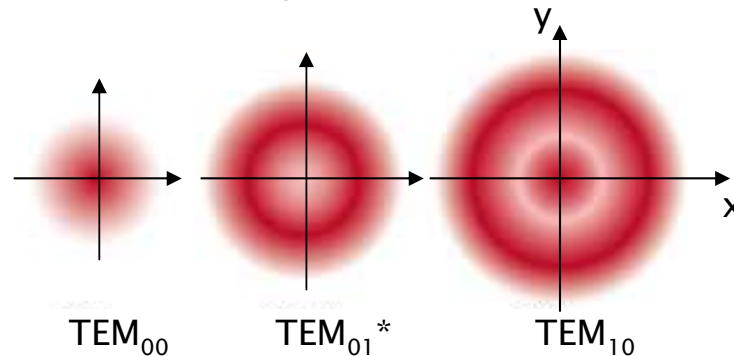

Development of the Coherence in a FEL

- Central mode TEM₀₀ (Gaussian) has the best overlap with the electron beam
 - ↳ fastest growth
 - ↳ increase of coherence
- Saturation in the last part of the undulator
 - ↳ other modes gain importance
 - ↳ decrease of coherence

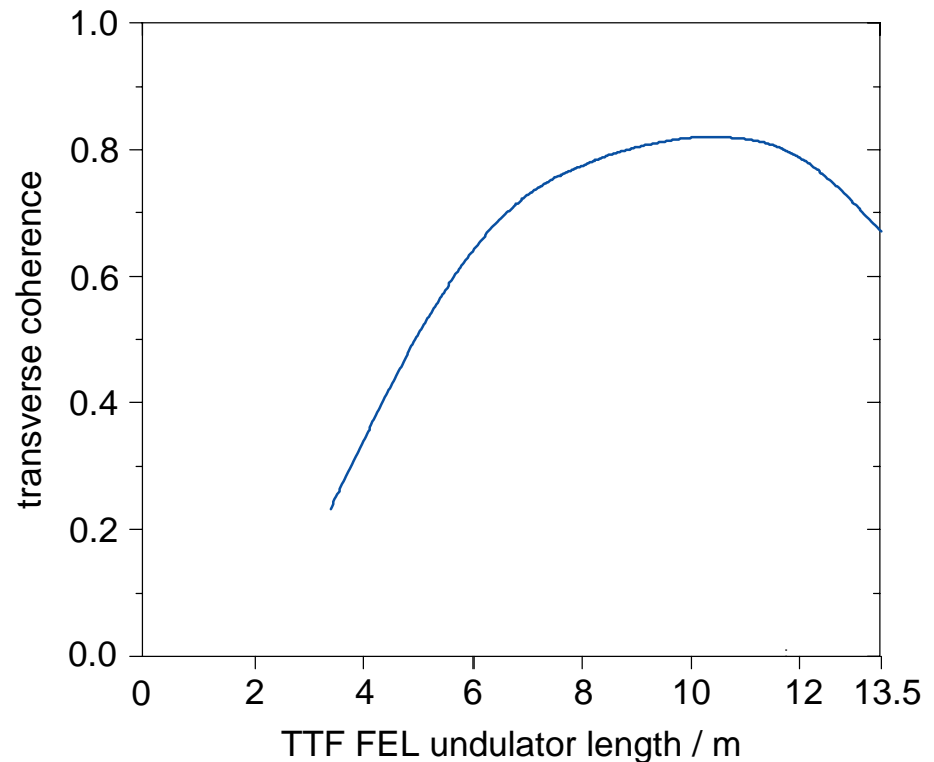

Simulations by Saldin, Schneidmiller, Yurkov

Rasmus Ischebeck, Transverse Coherence of a VUV Free Electron Laser

Measurement of Coherence by Interference Experiments

- Diffraction at a double slit:

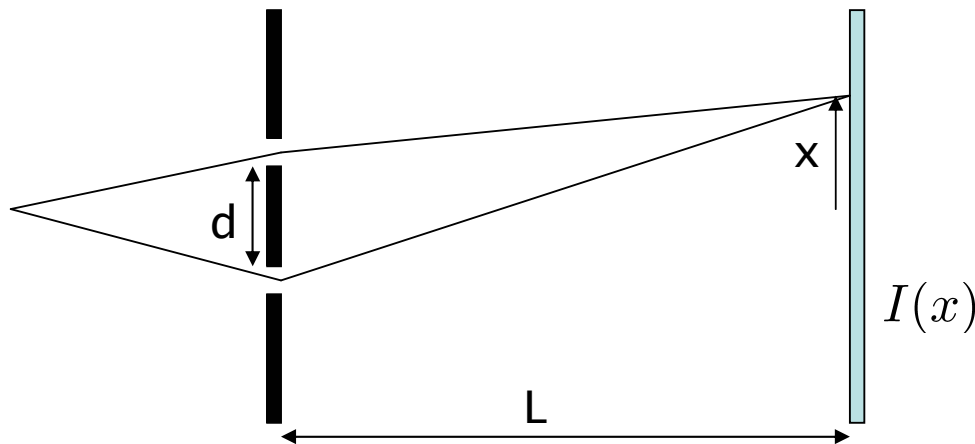

- Visibility of the interference fringes:

$$\mathcal{V} = \frac{I_{\max} - I_{\min}}{I_{\max} + I_{\min}}$$

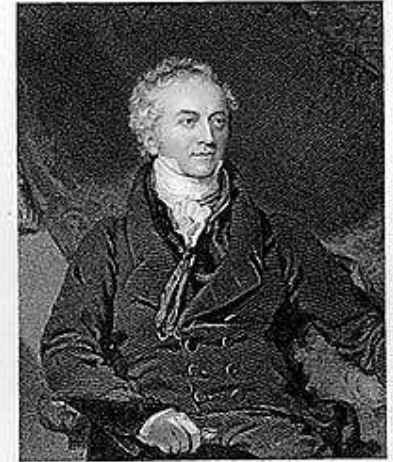

THOMAS YOUNG, F.R.S., F.R.A.S., F.R.S.E.
Thomas Young 1773-1829
Sci. B.S.

Fraunhofer diffraction at the double slit

- Far field condition

$$L \gg \frac{\pi d^2}{\lambda}$$

- Diffraction at double slits with separation d and width w

$$I(x) = I_0 \left(\frac{\sin(\pi w x / (\lambda L))}{\pi w x / (\lambda L)} \right)^2 \left[1 + \cos \left(2\pi \frac{d}{\lambda L} x \right) \right]$$

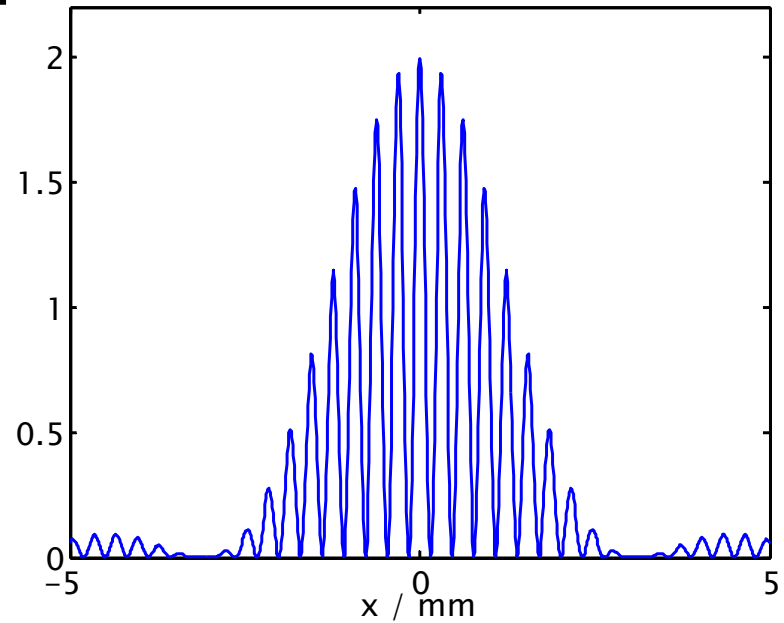

Fraunhofer diffraction with partially coherent light

- Let \mathcal{C} be the value of the coherence function between the two slits

$$I(x) = I_0 \left(\frac{\sin(\pi wx/(\lambda L))}{\pi wx/(\lambda L)} \right)^2 \left[1 + \mathcal{C} \cos \left(2\pi \frac{d}{\lambda L} x \right) \right]$$

- One can calculate the following visibility of the interference fringes

$$\mathcal{V} = \frac{I_{\max} - I_{\min}}{I_{\max} + I_{\min}} = \mathcal{C}$$

Fresnel diffraction at the double slits

- The diffraction pattern is modulated with the total amplitude \mathcal{S} :

$$I(x) = \mathcal{S}(x) \left[1 + \mathcal{V}(x) \cos \left(\frac{2\pi d}{\lambda L} x \right) \right]$$



Augustin Jean Fresnel

- This is the sum of the intensities of the single slit diffraction patterns

$$\mathcal{S}(x) = I_1(x) + I_2(x)$$

with

$$I_{1,2}(x) = \left(\frac{\sin(\pi w(x \pm d/2)/(\lambda L))}{\pi w(x \pm d/2)/(\lambda L)} \right)^2$$

- The visibility $\mathcal{V}(x)$ is now a function of x

Fresnel diffraction at the double slit

- Interference pattern

$$I(x) = \mathcal{S}(x) \left[1 + \mathcal{V}(x) \cos \left(\frac{2\pi d}{\lambda L} x \right) \right]$$

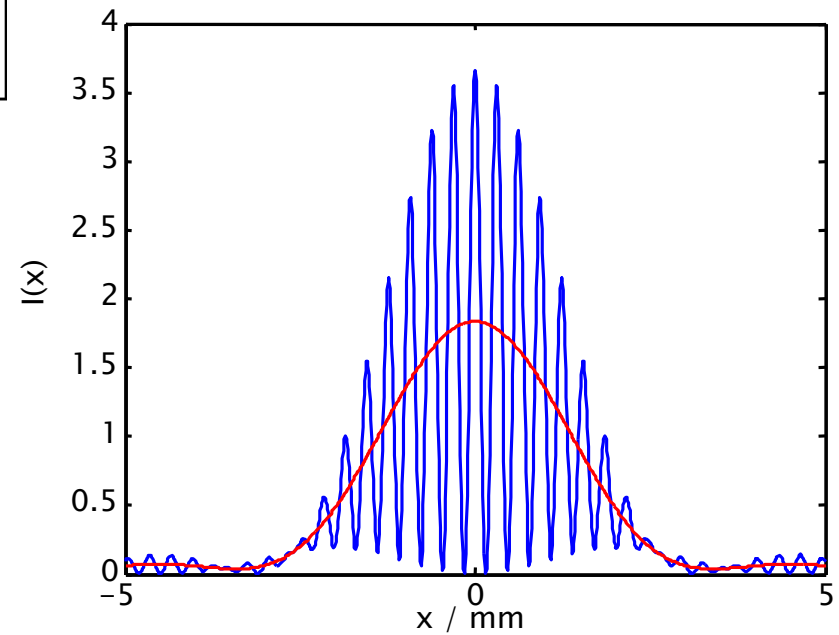
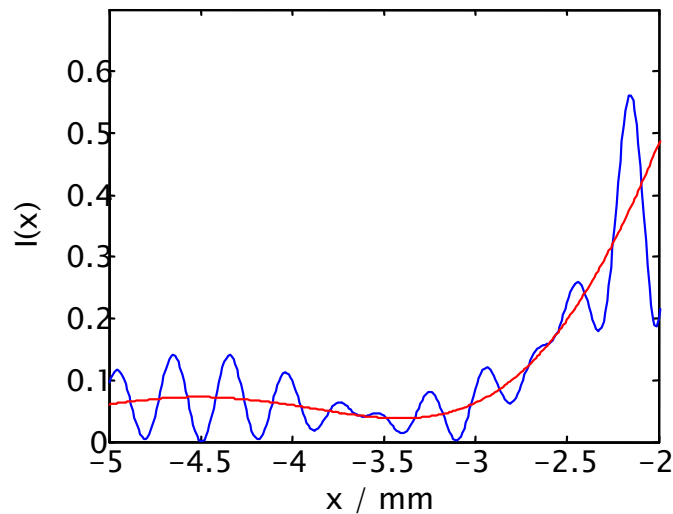

Transverse Coherence of a VUV Free Electron Laser

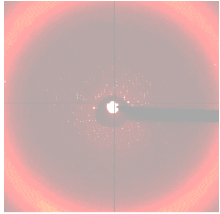

Introduction

- Relevance of Coherence
- Definition and Measurements

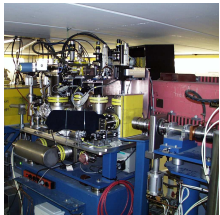

Measurements at the TTF FEL

- Challenges for the Measurements
- Experimental Setup

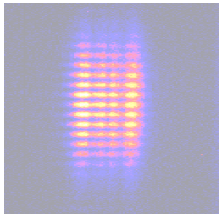

Results

- Coherence as a function of the slit separation
- Development along the undulator

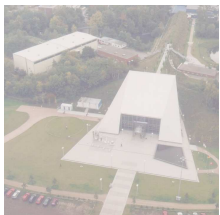

Outlook

- Phase 2 of the TTF FEL

Experimental Setup

TESLA Test Facility and VUV FEL

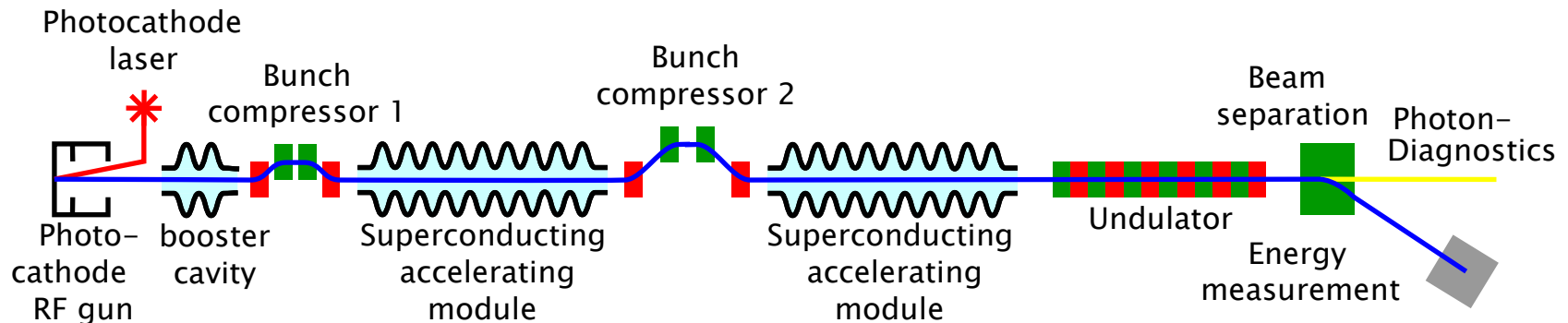

- Length: 120m
- Electron energy: 260MeV
- Peak current: 1 kA
- Wavelength of the FEL: 100nm
- Peak power of the FEL: 1GW
- Pulse energy: 10...100 μ J
- Brilliance of the FEL: $4 \cdot 10^{28}$ photons / (s mm² mrad² 0.1% bandwidth)

Experimental Setup

TESLA Test Facility and VUV FEL

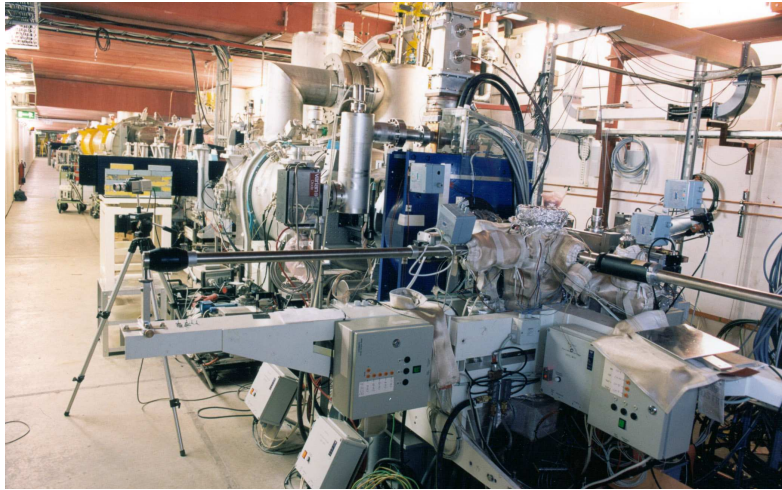

Injector



Superconducting
accelerating module

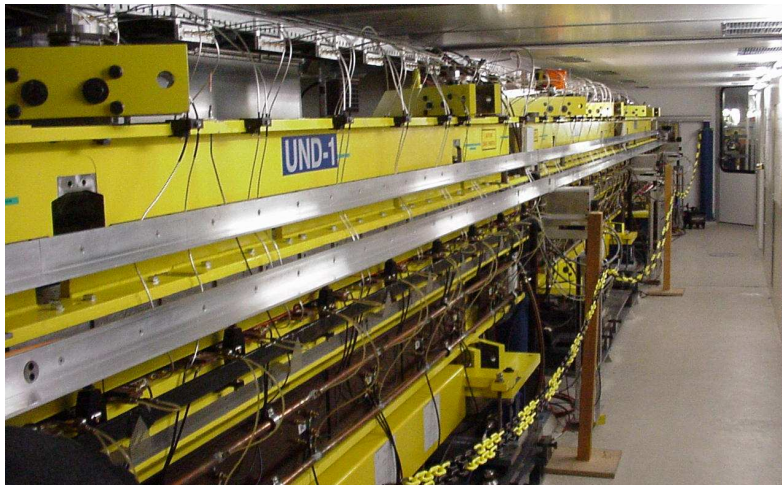

Undulator

Rasmus Ischebeck, Transverse Coherence of a VUV Free Electron Laser

Experimental Setup

The TTF Free Electron Laser

Differences to conventional lasers:

- Large fluctuations in the intensity and wavelength because of
 - the stochastic nature of the radiation
 - instabilities of the electron beam
- There is no optical resonator which limits the radiation to the central mode
 - transverse coherence only within the modes
- Radiation is emitted in a single passage of the ultra-relativistic electron bunch
 - limited longitudinal coherence

Experimental Setup

Spectra

- Measurement of the camera behind the monochromator
- Intensity as a function of wavelength

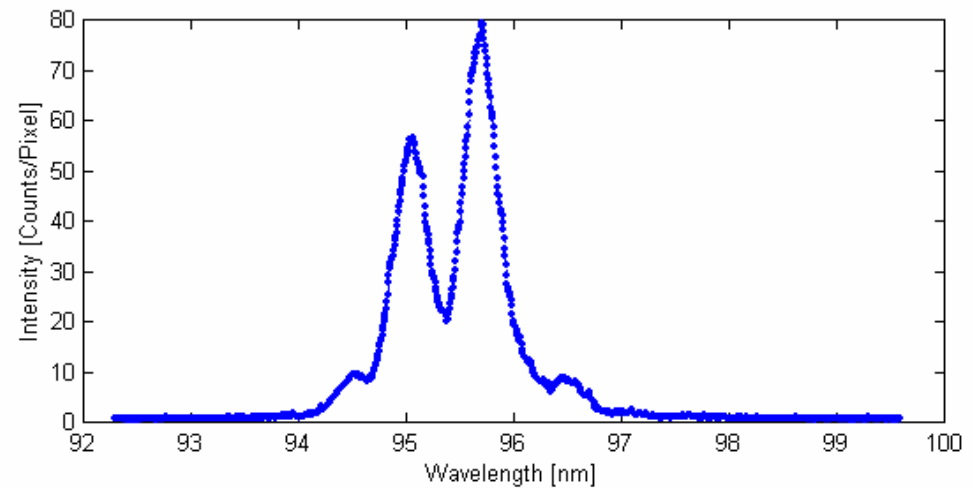
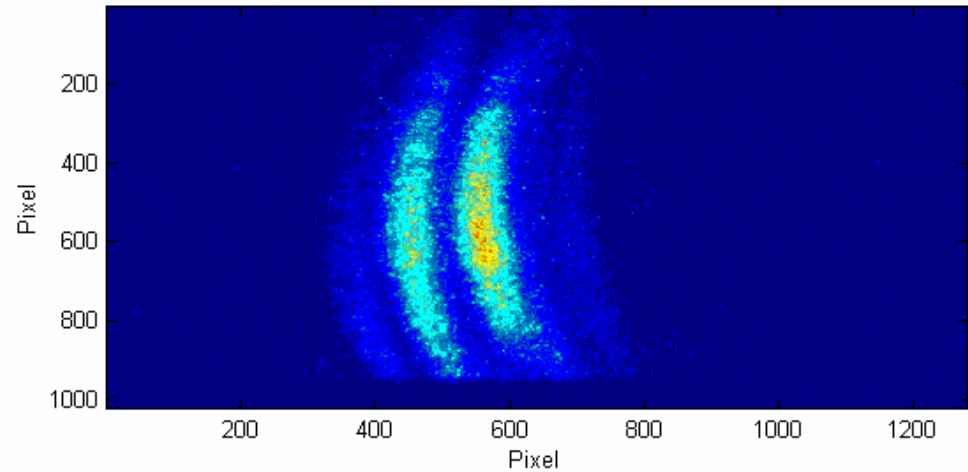

Experimental Setup

The TTF Free Electron Laser

Considerations for experiments using this radiation:

- Wavelength of 100nm: vacuum ultraviolet (VUV)
 - is absorbed by any material
 - no possibility to extract the beam from the vacuum chamber
 - the complete setup has to be enclosed in the dust-free ultra high vacuum of the accelerator
- High intensity of the FEL:
 - 10...100 μj in 100fs, that is 1GW on 10mm²
 - Usage of a two-step detector:
 - Conversion to visible light in a Ce:YAG crystal
 - Diffraction pattern is imaged onto a CCD chip
 - What is the resolution of this detector?
 - Cooling of apertures and fluorescent crystals

Experimental Setup

Photon diagnostics at the TTF FEL

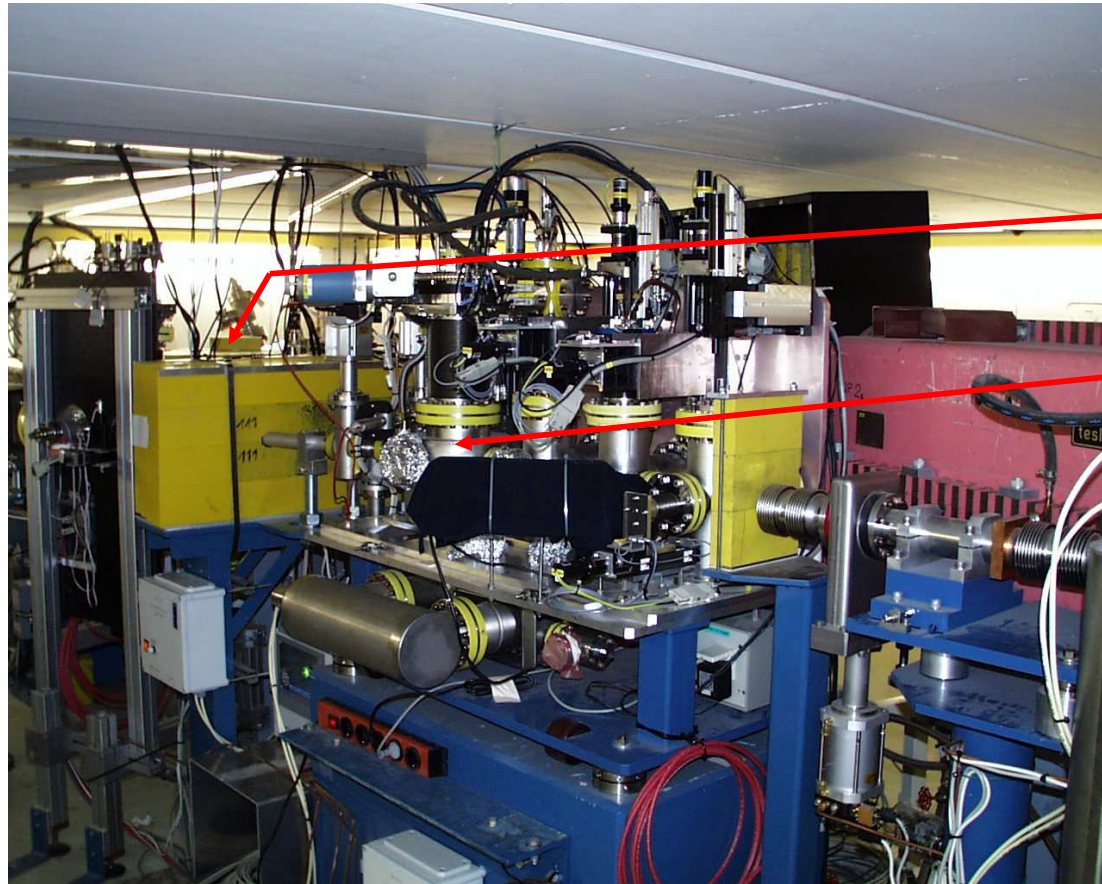

Crystal and camera

Double slit

Photons

Experimental Setup

Photon Diagnostics at the TTF FEL

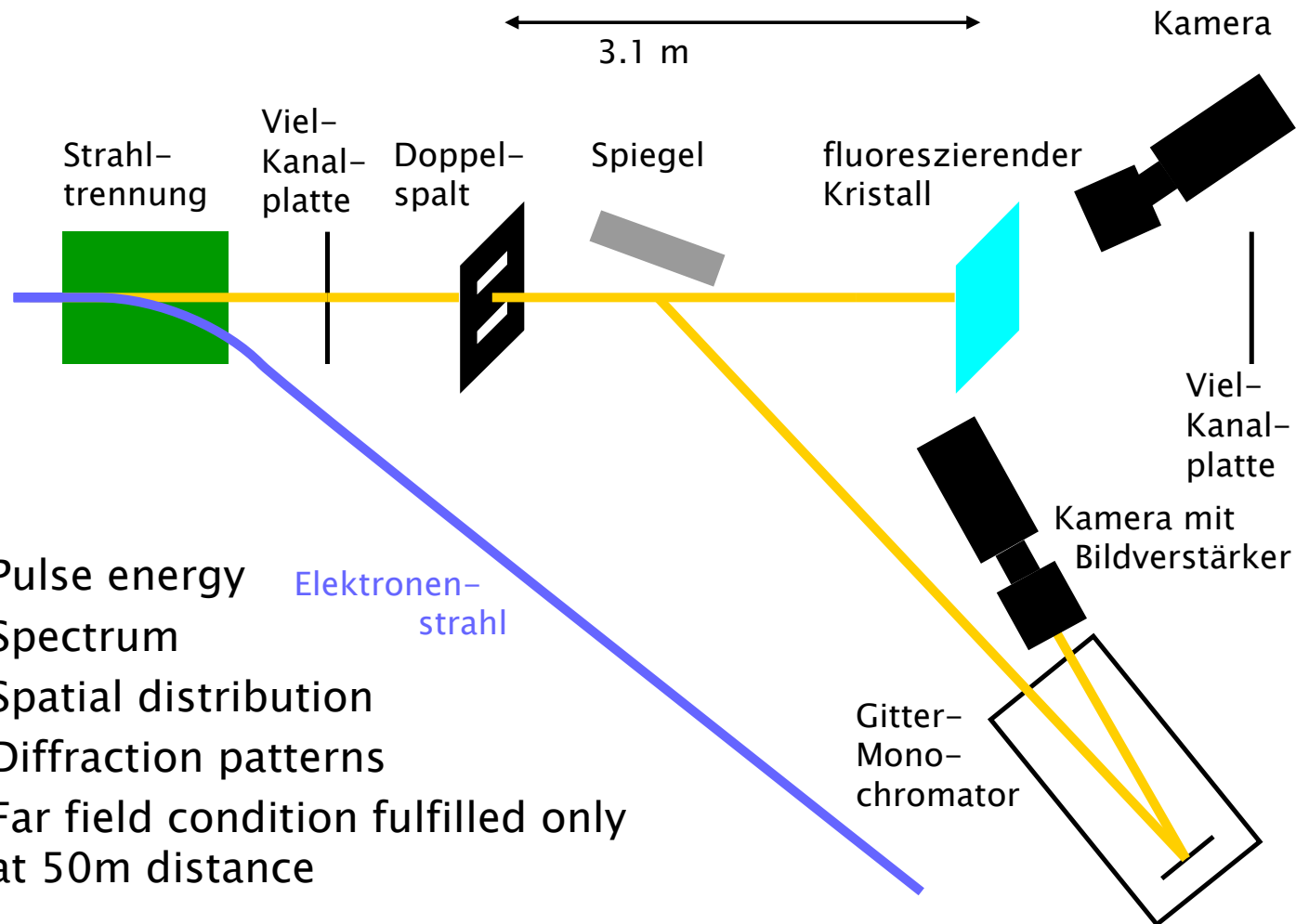

- Pulse energy
- Spectrum
- Spatial distribution
- Diffraction patterns
- Far field condition fulfilled only at 50m distance

Experimental Setup Double Slits

- Laser cut into stainless steel foil

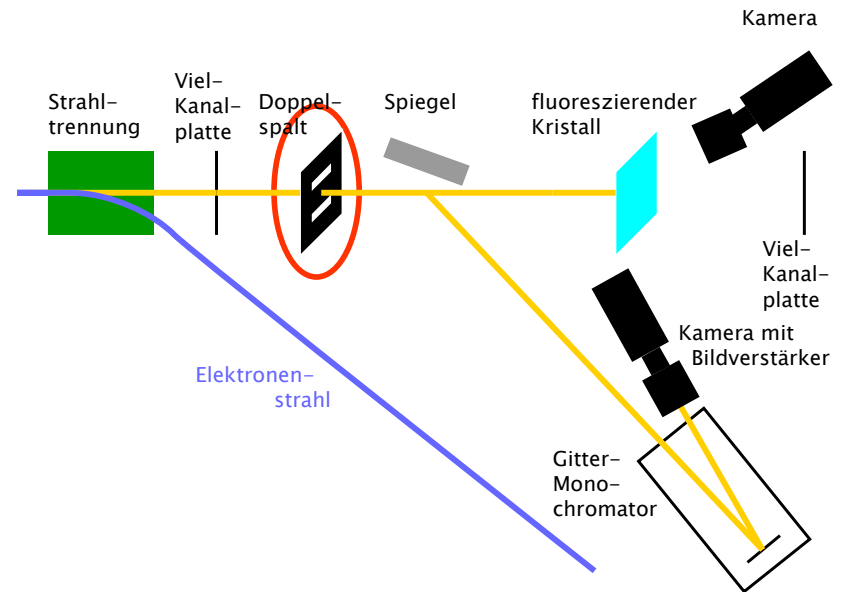
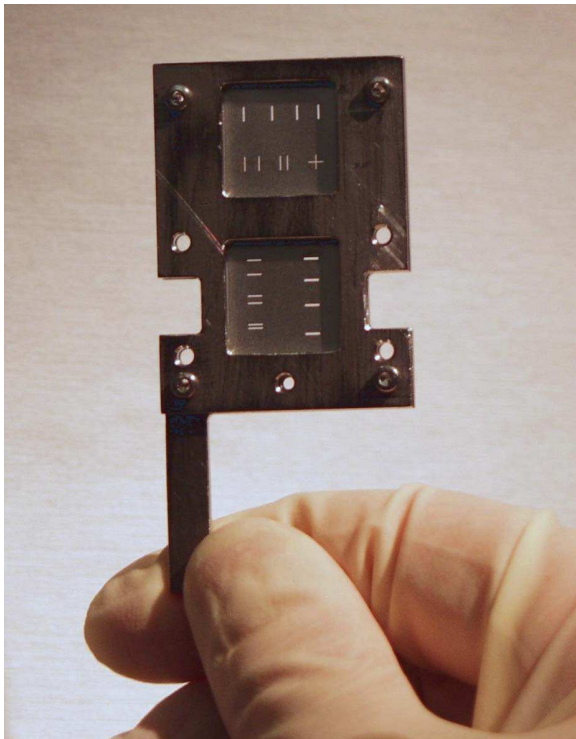

- Slit separations: 0.5, 1, 2 und 3mm
- Slit width: 100 μ m
- Slit length: 2mm
- Positioned by two stepper motors

Experimental Setup Fluorescent Crystal



Ce:YAG crystal

on a watercooled frame

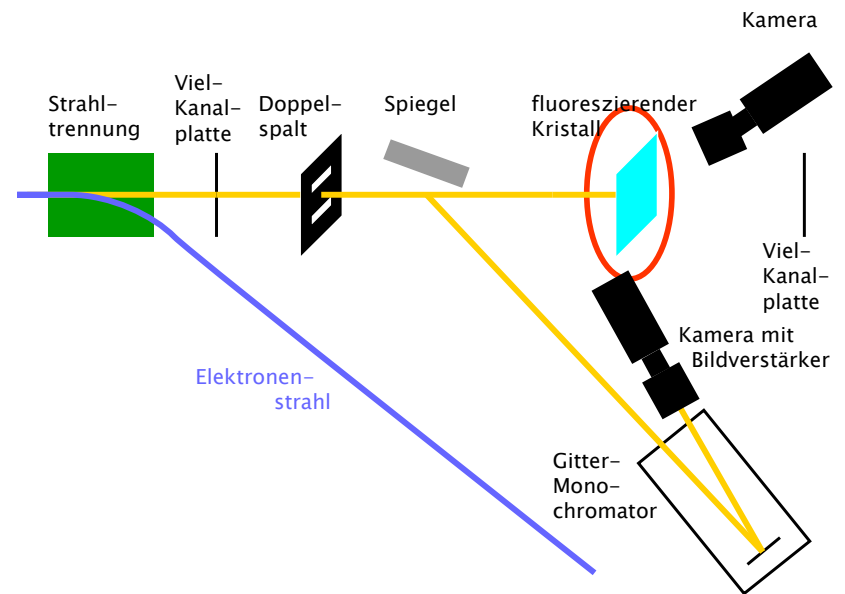

Experimental Setup Camera

- The space behind the crystal is occupied by another detector
- Camera looks on the crystal under an angle of 45°
- Tilted lens for good focusing over the inclined crystal

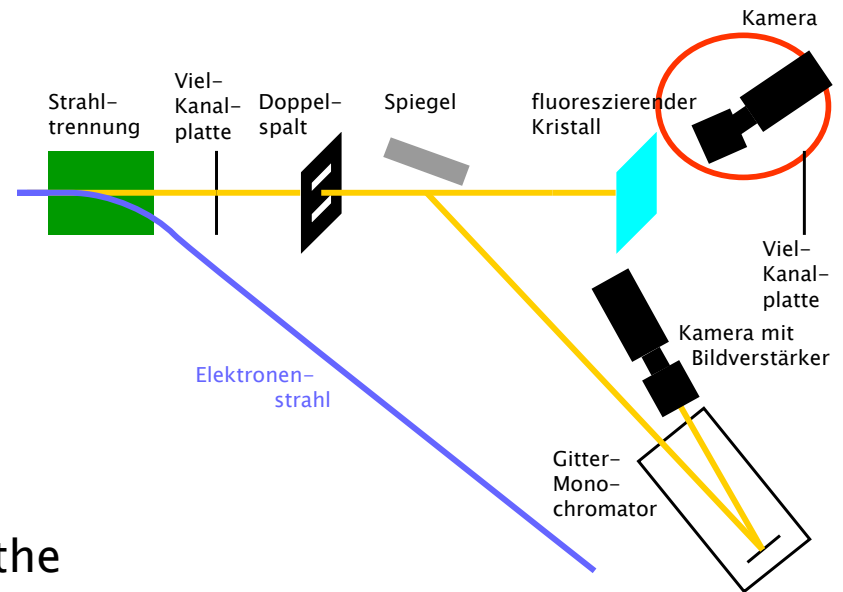

Transverse Coherence of a VUV Free Electron Laser

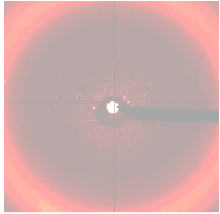

Introduction

- Relevance of Coherence
- Definition and Measurements



Measurements at the TTF FEL

- Challenges for the Measurements
- Experimental Setup

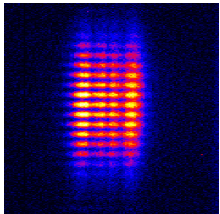

Results

- Coherence as a function of the slit separation
- Development along the undulator

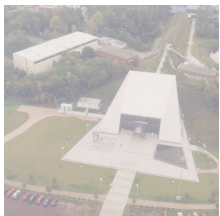

Outlook

- Phase 2 of the TTF FEL

Diffraction Patterns

- Single images

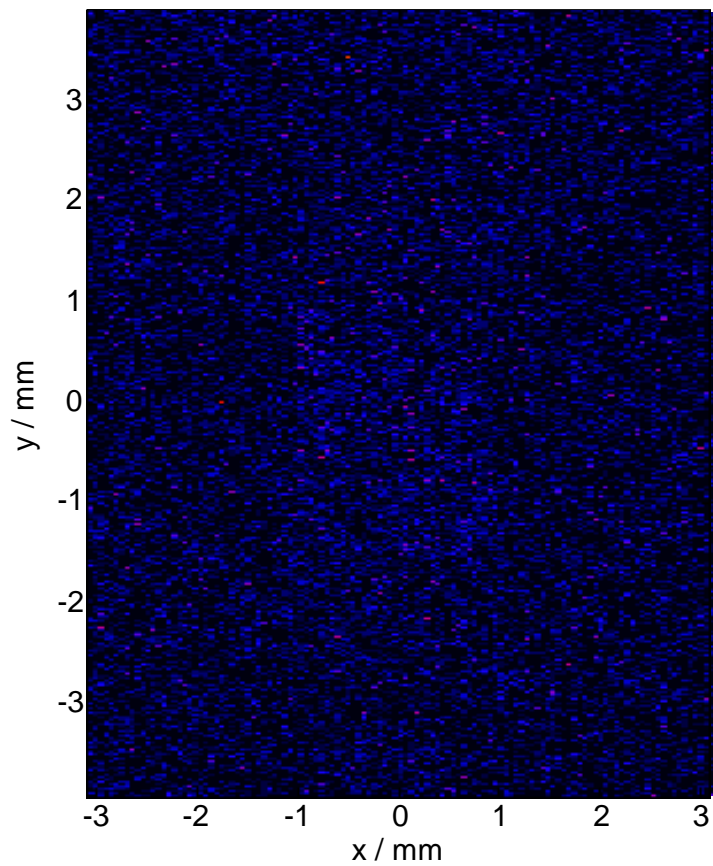

- Average of 100 images

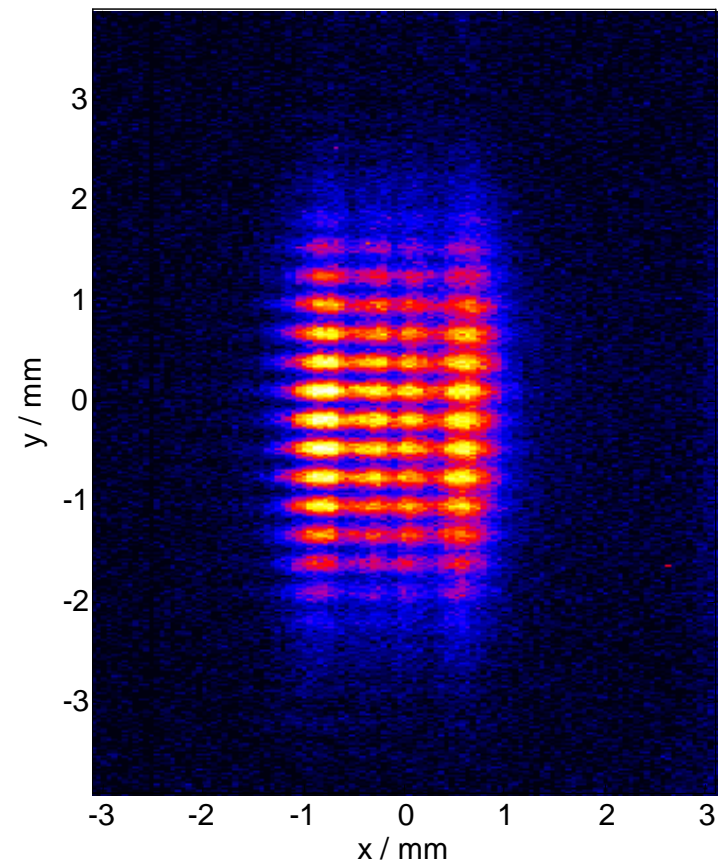

Effects of the Experimental Setup

- Fluorescent crystal (Ce:YAG):
 - Resolution: measured with the photo cathode laser
 - Saturation / non-linear response function: measured with the FEL
- Camera
 - Resolution: measured with a test pattern and a point-like light source
- CCD chip
 - Noise: measured on the unexposed chip

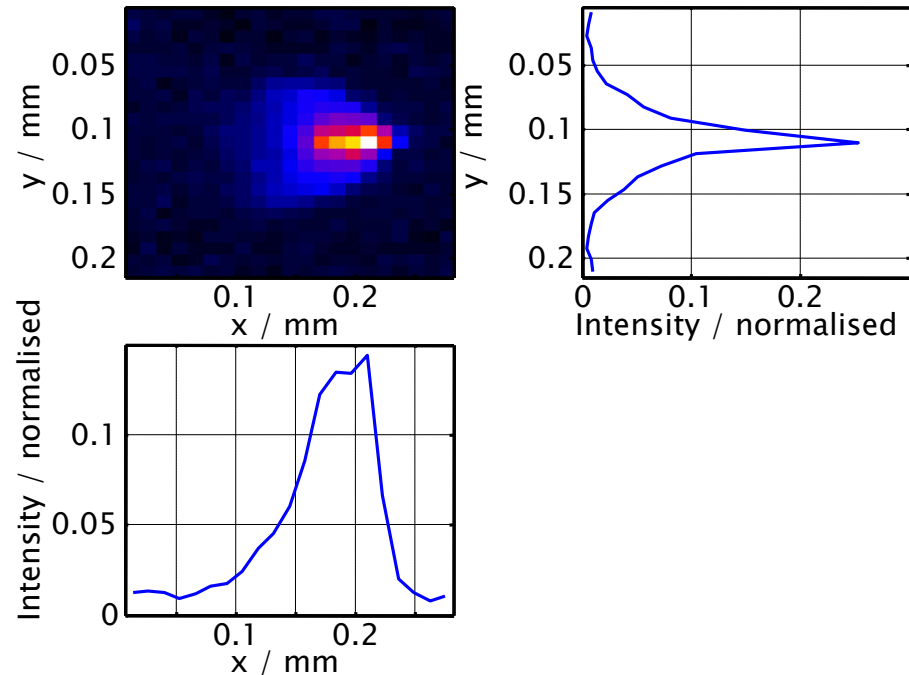

Deconvolution of the Resolution

- The measured image is influenced by lens errors and by diffraction at the aperture
- Description as a convolution of the true distribution Ψ with the **Point Spread Function P**:

$$\Phi(x, y) = \int_{-\infty}^{\infty} \int_{-\infty}^{\infty} P(x - u, y - v) \cdot \Psi(u, v) du dv$$

- For discrete distributions:

$$\Phi_{i,k} = \sum_{m,n} P_{i-m,k-n} \cdot \Psi_{m,n}$$

⇒ Reduced contrast

⇒ seemingly reduced coherence of the FEL

Deconvolution of the Resolution

- If P is known, the system of equations can in principle be solved for Ψ
- But: noise in the measured image is strongly amplified and results in negative values for the true intensity

- The intensity can be reconstructed with the **Lucy–Richardson Algorithm**
 - Iterative algorithm
 - Maximize the likelihood of the measurement, with given boundary conditions

Image Processing

Deconvolution of the Resolution

- uncorrected image

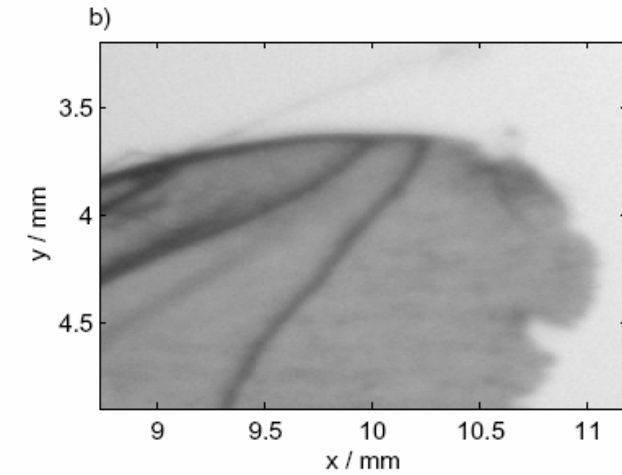
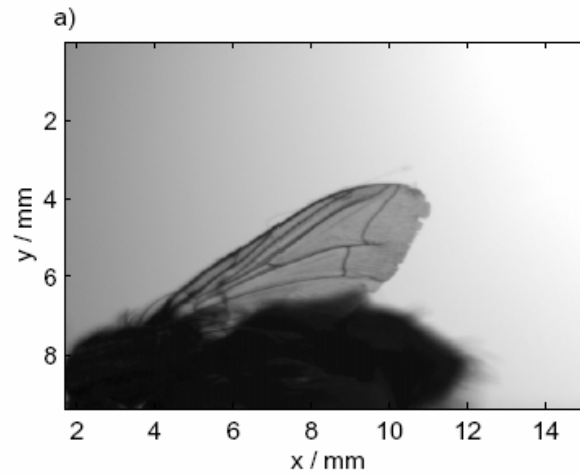

- deconvoluted with the Lucy-Richardson Algorithm

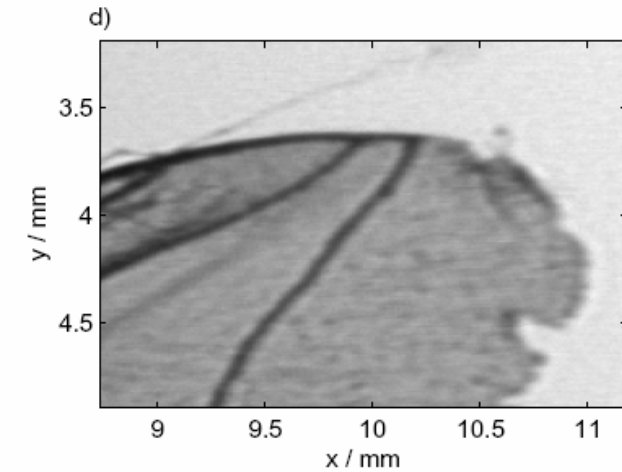
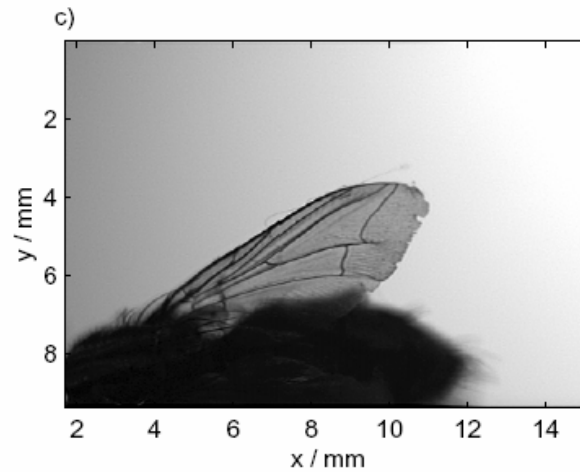
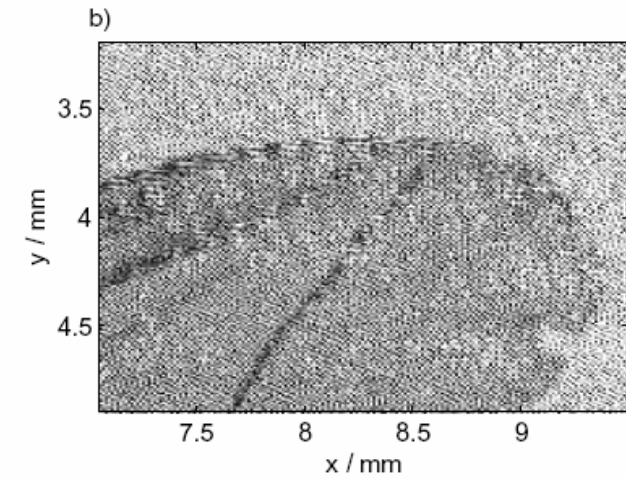
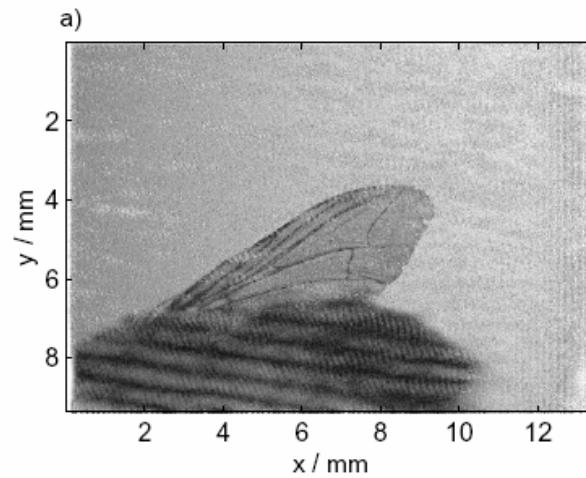

Image Processing

Deconvolution of the Resolution

- “Corrected”
by solving the
system of
equations



- deconvoluted
with the
Lucy-
Richardson
Algorithm

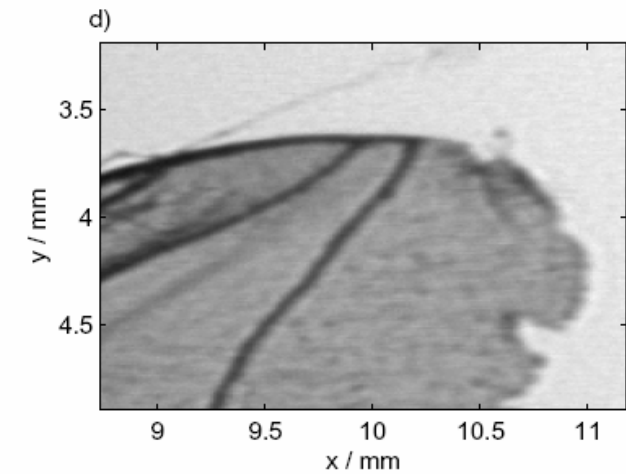
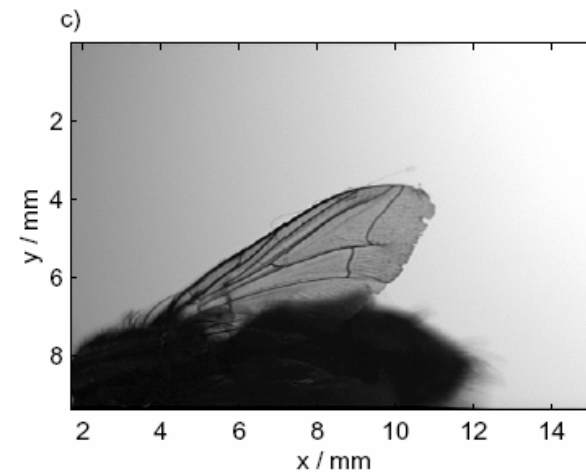

Deconvolution of the Resolution

Measurement of modulation transfer function (MTF) with a test pattern

Measurement of the improvement by applying the Lucy-Richardson algorithm

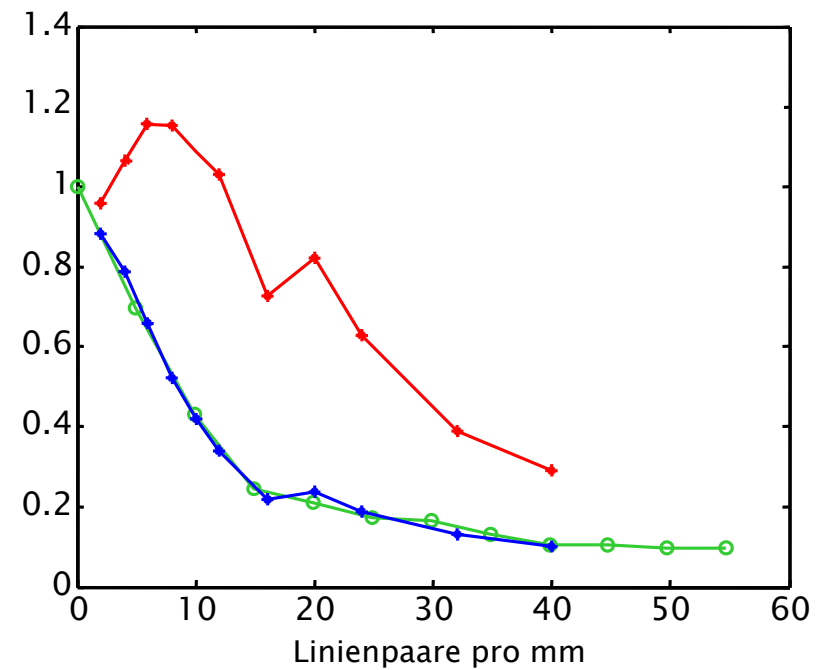
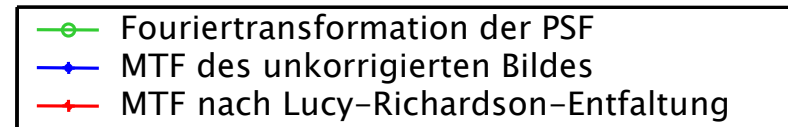
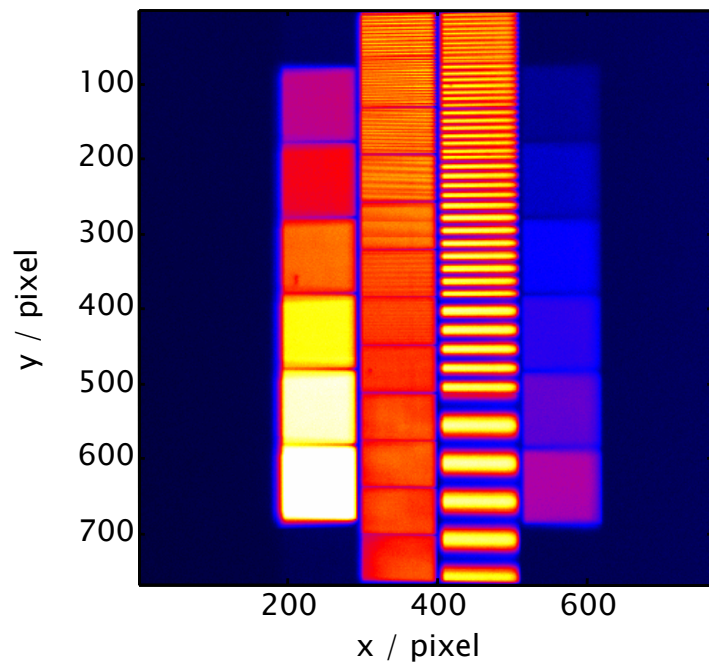
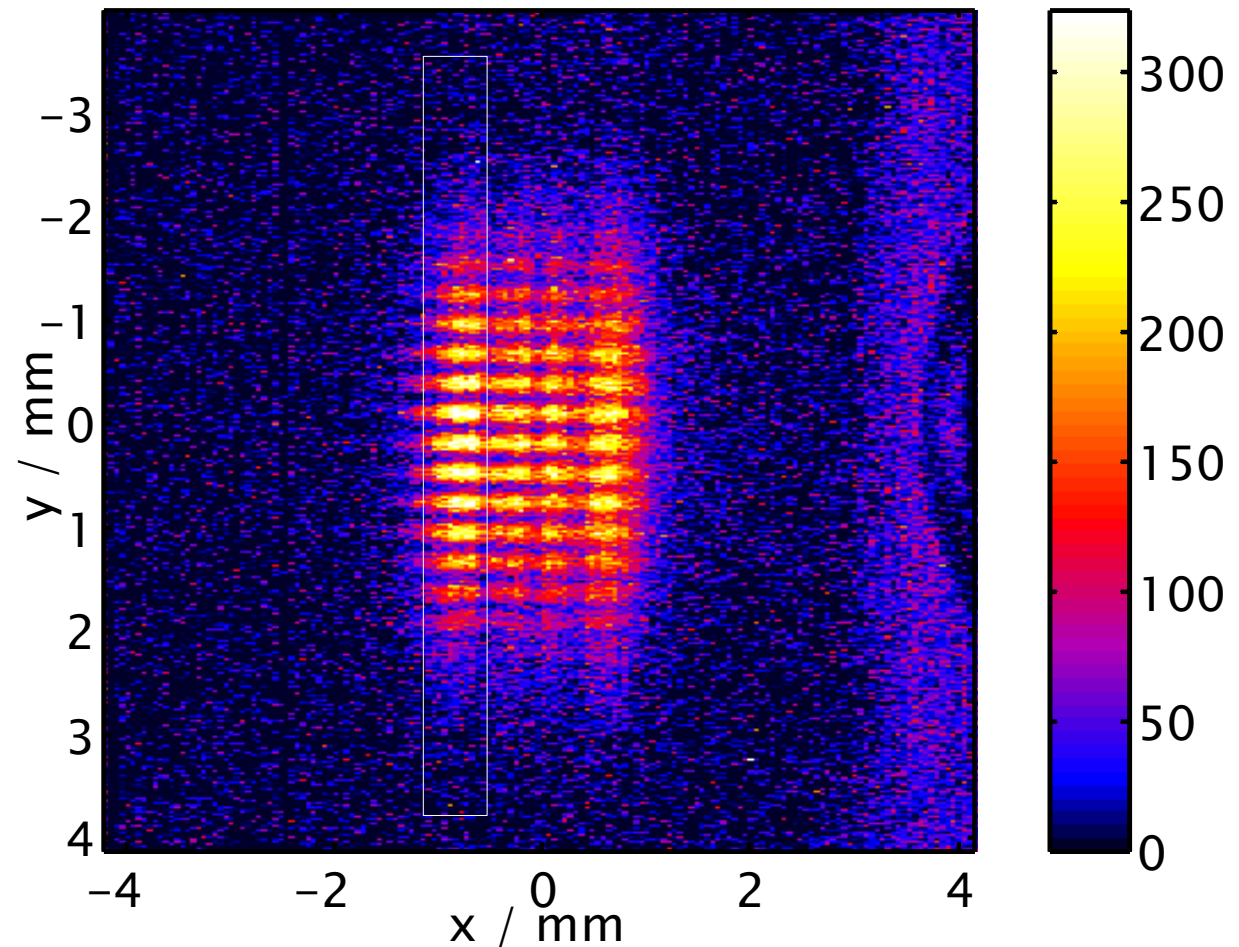

Image Processing

Corrected Diffraction Pattern

Corrections:

- Non-linearity
- Resolution



Analysis

- Goal of the analysis: determine the coherence function
- In the far field, with a perfect experimental setup:
 - coherence is equal to the visibility of the interference fringes:
$$\mathcal{C} = \mathcal{V}$$
- Here:
 - near field effects
 - detrimental effects of the setup
- Two analysis methods will be presented:
 1. Visibility of the interference fringes
 2. Fit to the intensity distribution
- Simulation of the effects for comparison
 - Application of the analysis to simulated images

Analysis 1:

Visibility of the Interference Fringes

- Project the selected region of the diffraction pattern
- Smooth the projection with a digital filter
- Find maxima and minima

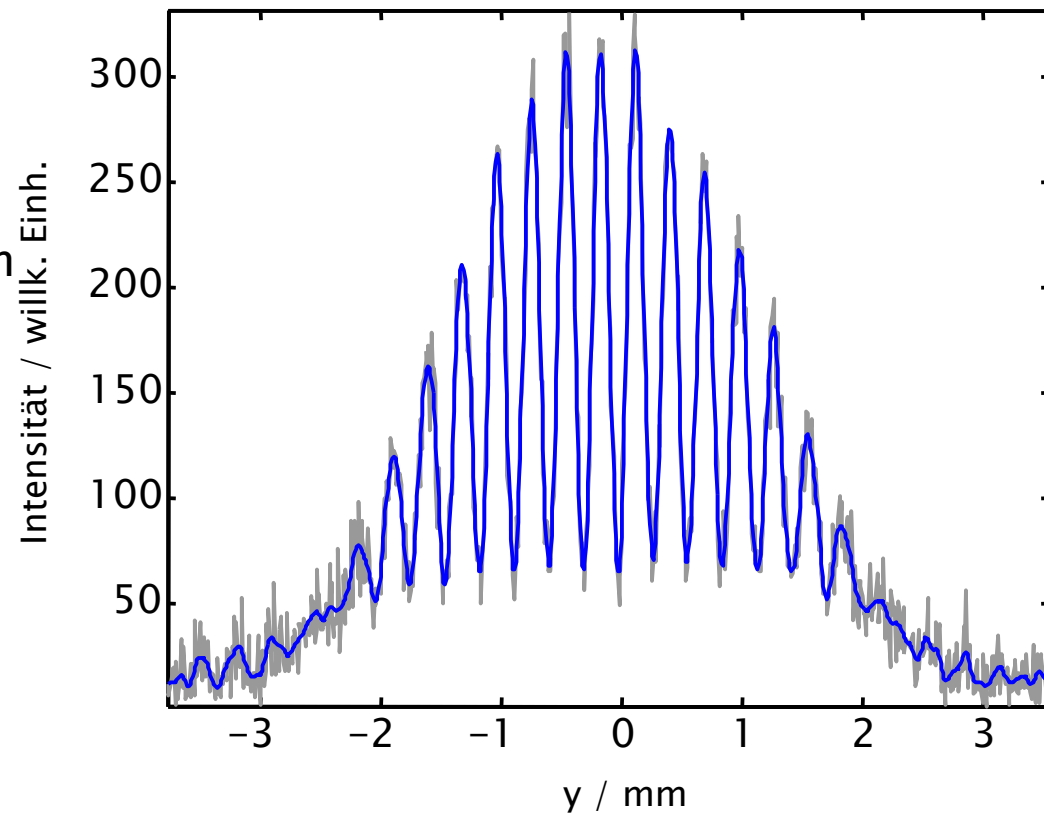

Analysis 1:

Visibility of the Interference Fringes

- Compute the visibility

$$\mathcal{V} = \frac{I_{\max} - I_{\min}}{I_{\max} + I_{\min}}$$

from the maxima and minima of the curve

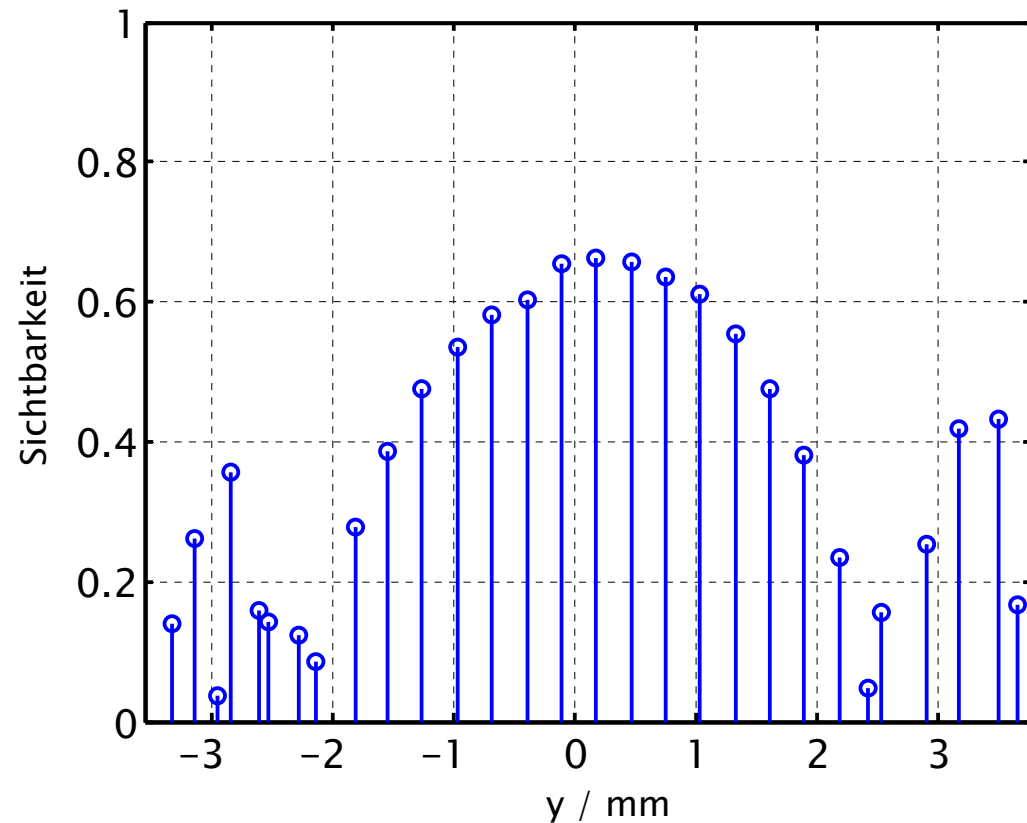

Analysis 2:

Fit to the Intensity Distribution

Fit 7 parameters:

- degree of coherence
- middle
- intensity in front of the left slit
- intensity in front of the right slit
- direction of the wave vector in front of the left slit
- direction of the wave vector in front of the right slit
- wavelength

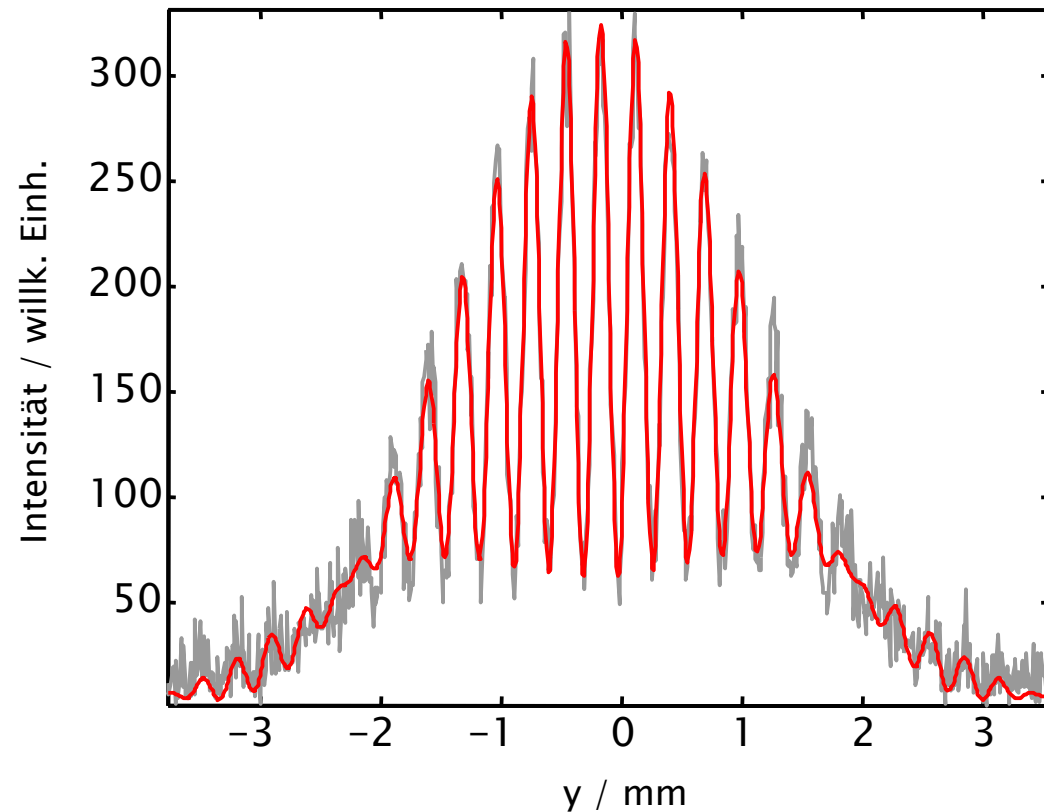

Results of the Measurements: Coherence as a Function of the Separation

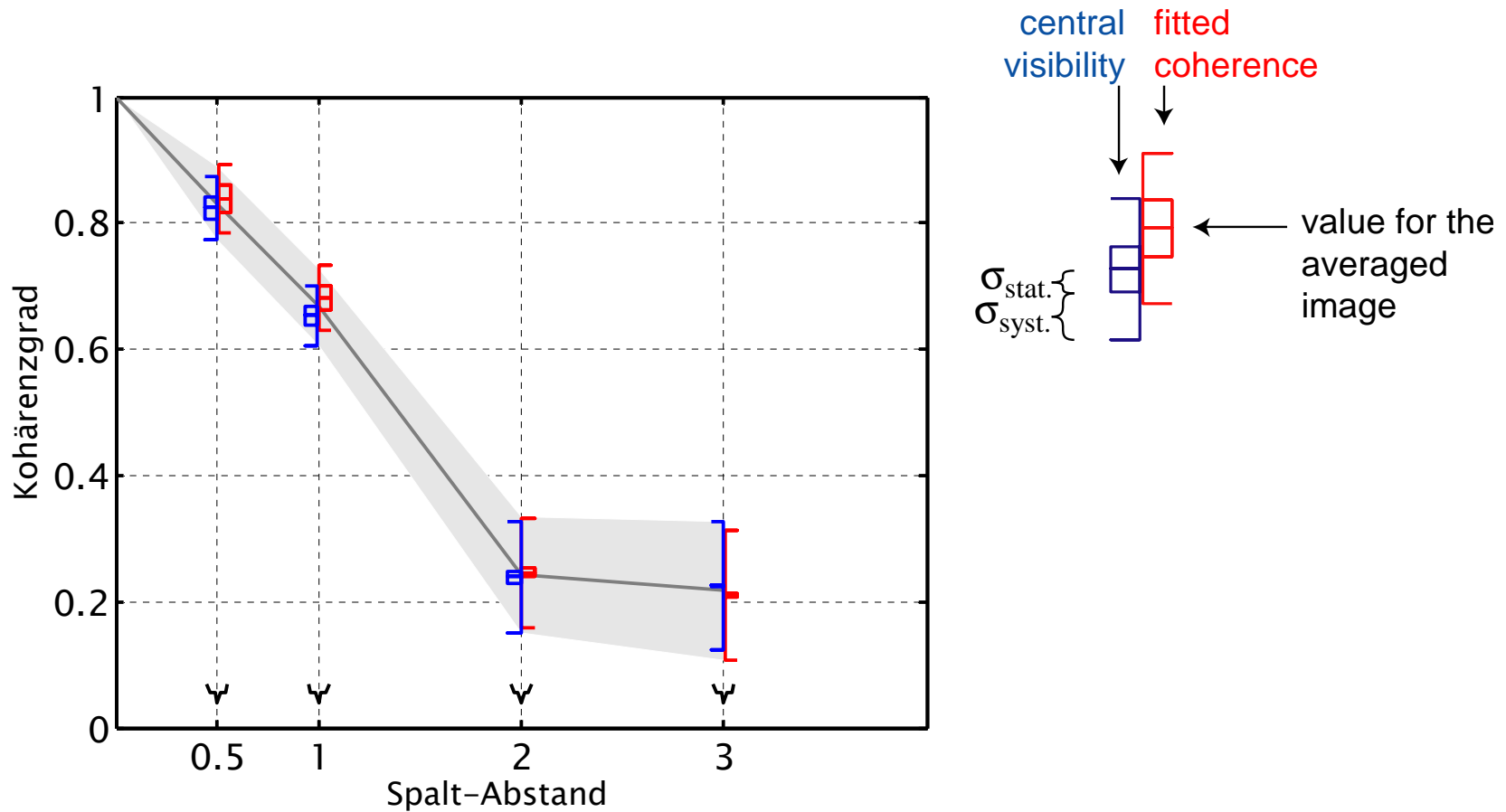

Simulation of the Experiment

- Goal of the simulations:
 - compare the simulation results to the measurements
 - review of the image processing and analysis routines
- Simulation of
 - FEL process (M. Yurkov)
 - near field diffraction
 - detrimental effects of the experimental setup
 - fluorescent crystal
 - scatter, measured with the photocathode laser
 - linearity, measured by comparing to a calibrated detector
 - camera lens, measured with test slide and pinhole aperture
 - CCD detector

Simulation of the Experiment Overview

Comparison of measured
and simulated images

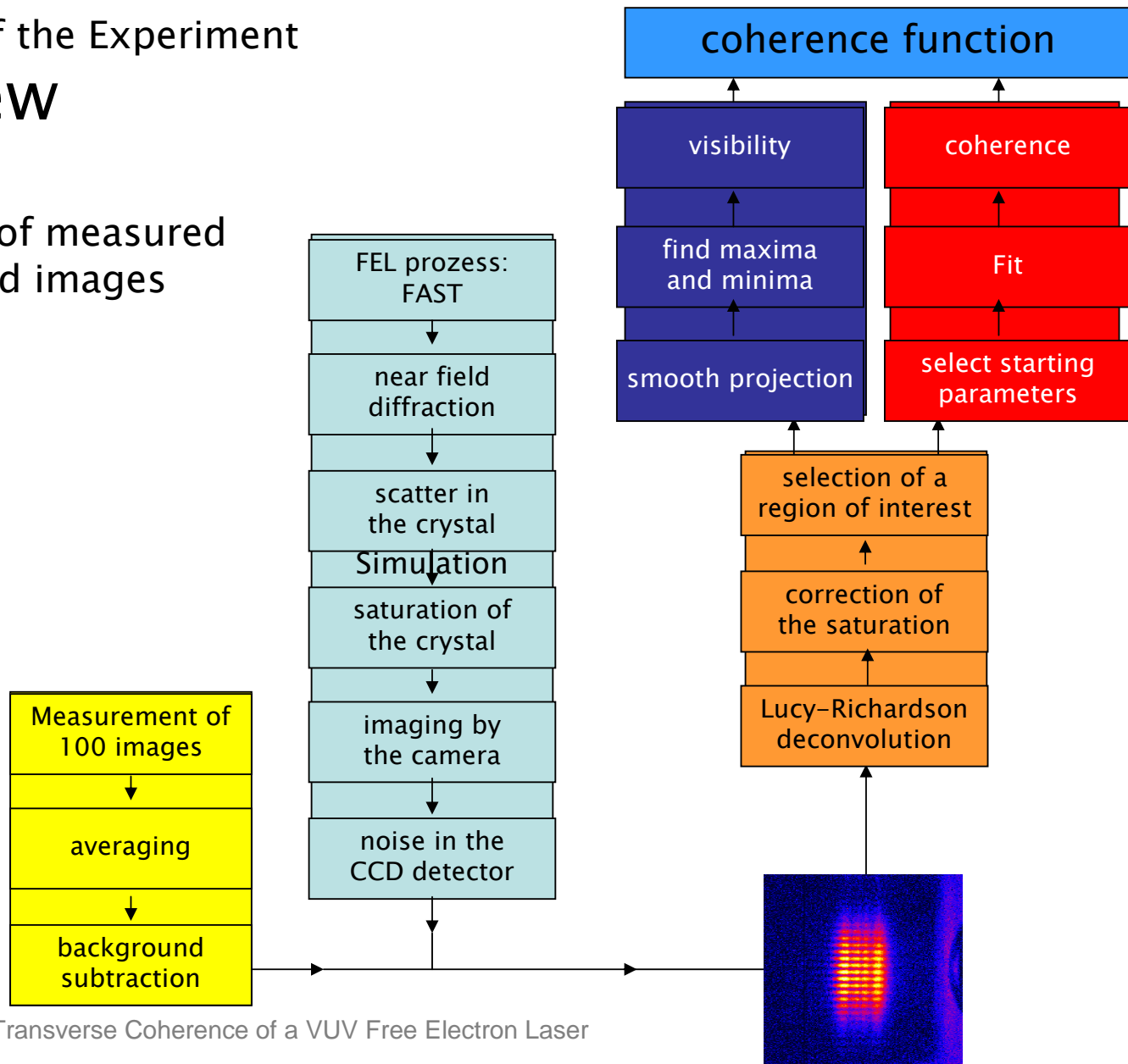

Simulation of the Experiment

Interference Effects

Near field diffraction (GLAD)

- Representation as classic electromagnetic field with a slowly varying amplitude
- Computation of diffraction effects
 - in Fourier space
 - on a grid

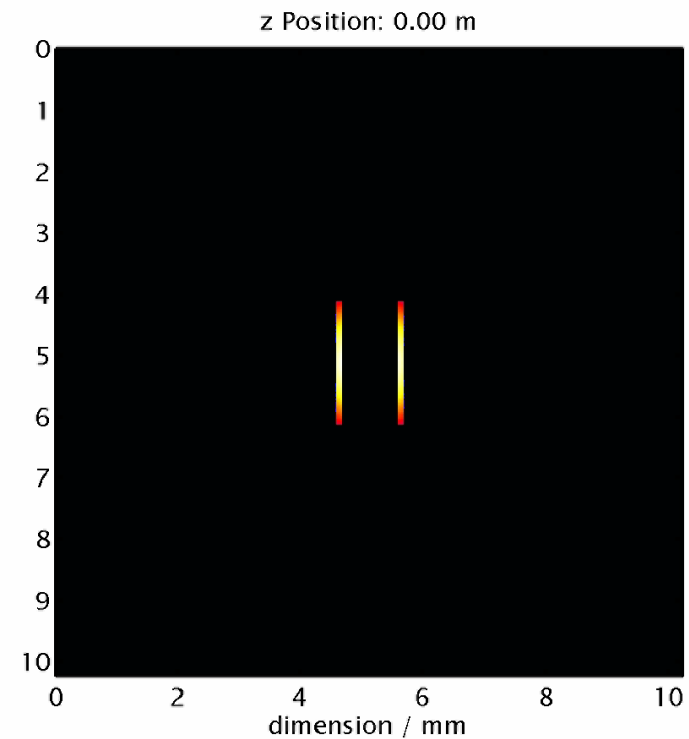

Simulation of the Experiment

Simulation of the Experimental Setup

- Fluorescent crystal
 - scatter: convolution with a Gaussian distribution
 - Non-linearity
- Imaging by the camera: convolution with the measured point spread function
- CCD detector: addition of pixel noise

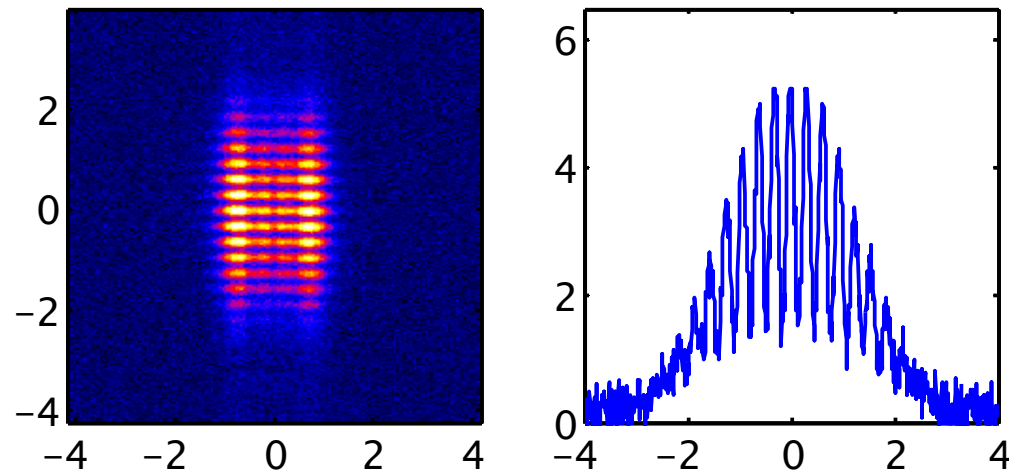

Simulation of the Experiment

Analysis of Simulated Images

- Deconvolution of the resolution
- correction of the non-linearity of the fluorescent crystal
- Projection of a selected region
- Application of the analysis methods
 - visibility of the interference fringes
 - fit to the intensity distribution

- The correlation function of the wave can be calculated directly in front of the double slit

⇒ Compare the results of the analysis with the correlation function

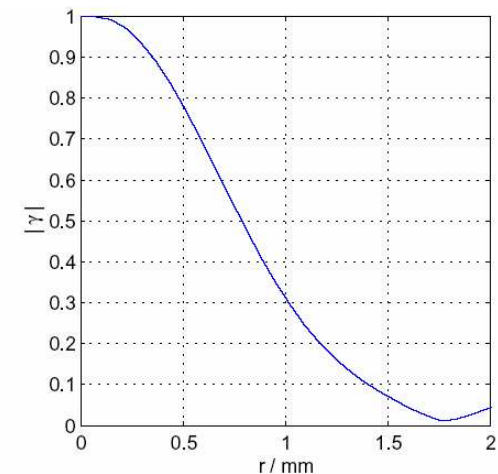
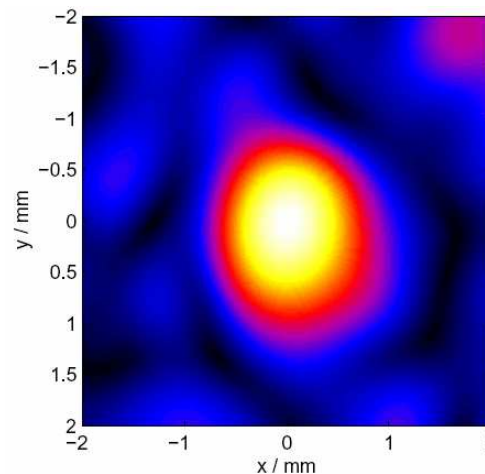

Simulation of the Experiment Results

- Coherence is higher than in the measurements
- Distortion of the wave front
- New version of FAST results in a smaller coherence

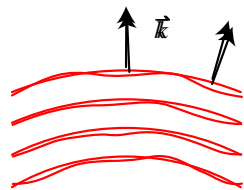

Rasmus Ischebeck, Transverse Coherence of a VUV Free Electron Laser

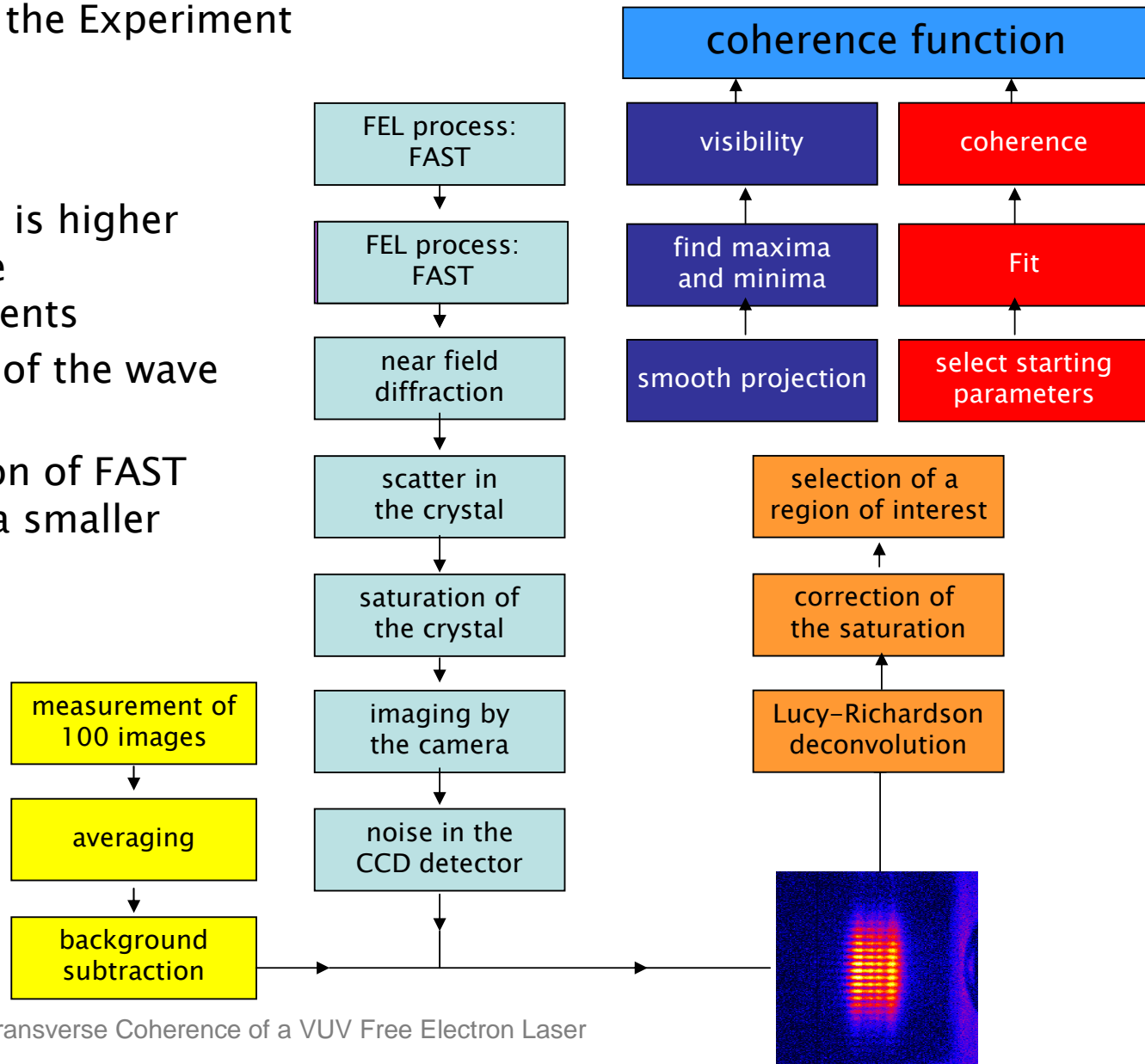

Simulations: Summary

Simulations of

- FEL process
- Adjustment of the coherence function by distortion of the wave fronts
- Near field (Fresnel) diffraction
- Detrimental effects of the experimental setup

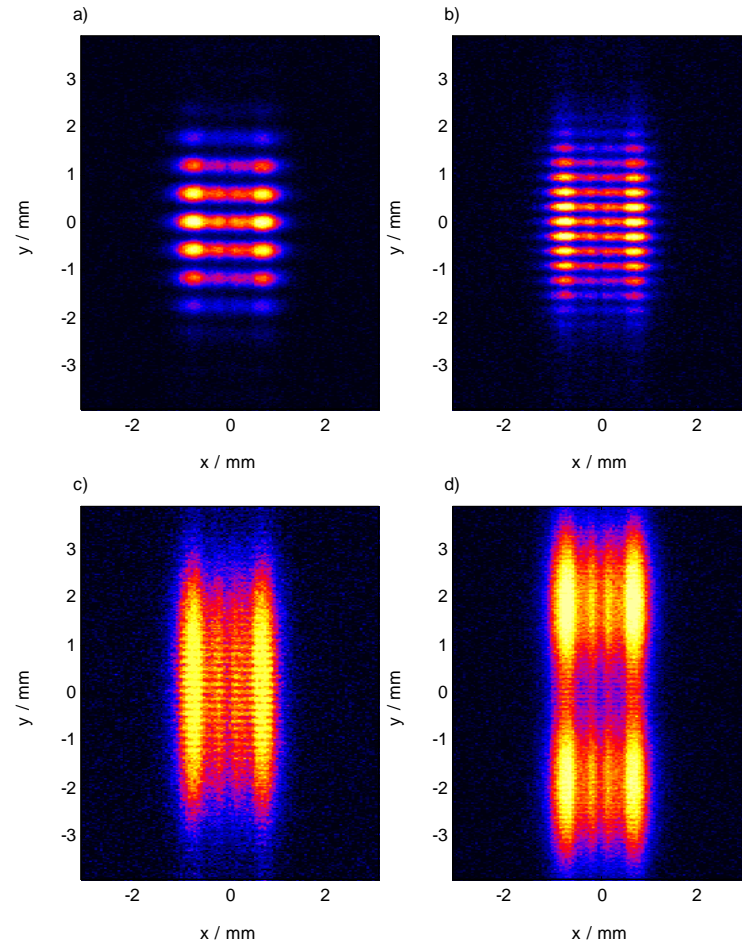

Simulations:

Spatial Coherence as a function of Slit Separation

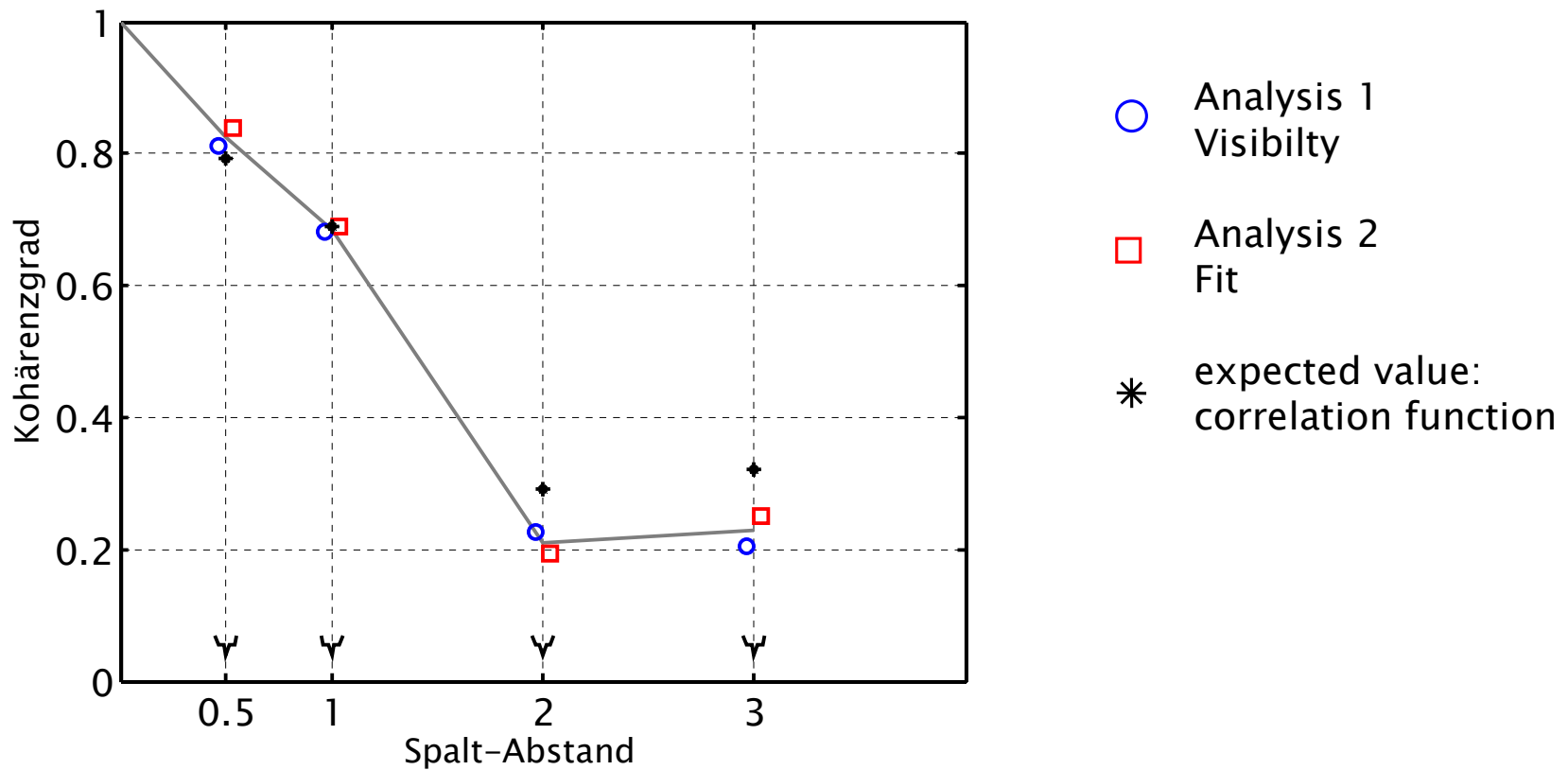

Reminder: Result of the Measurements

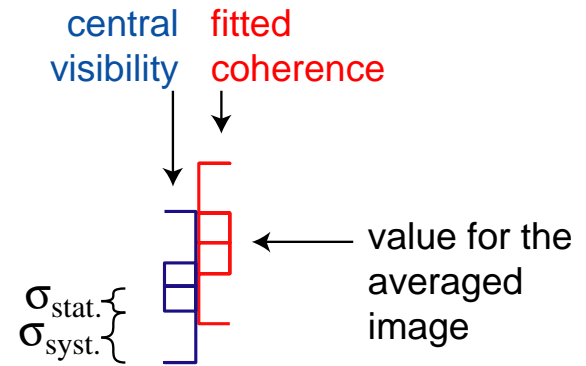
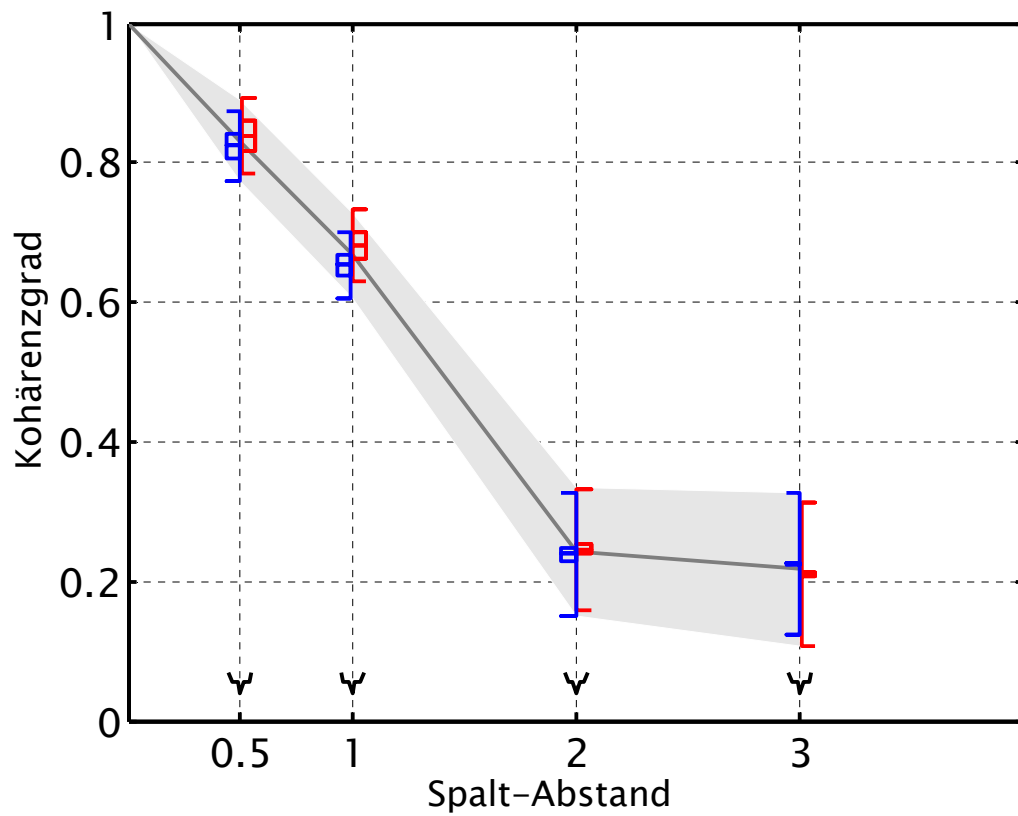

Evolution of the Coherence along the Undulator

- Reminder: theoretic prediction
- How can the undulator length be adjusted?

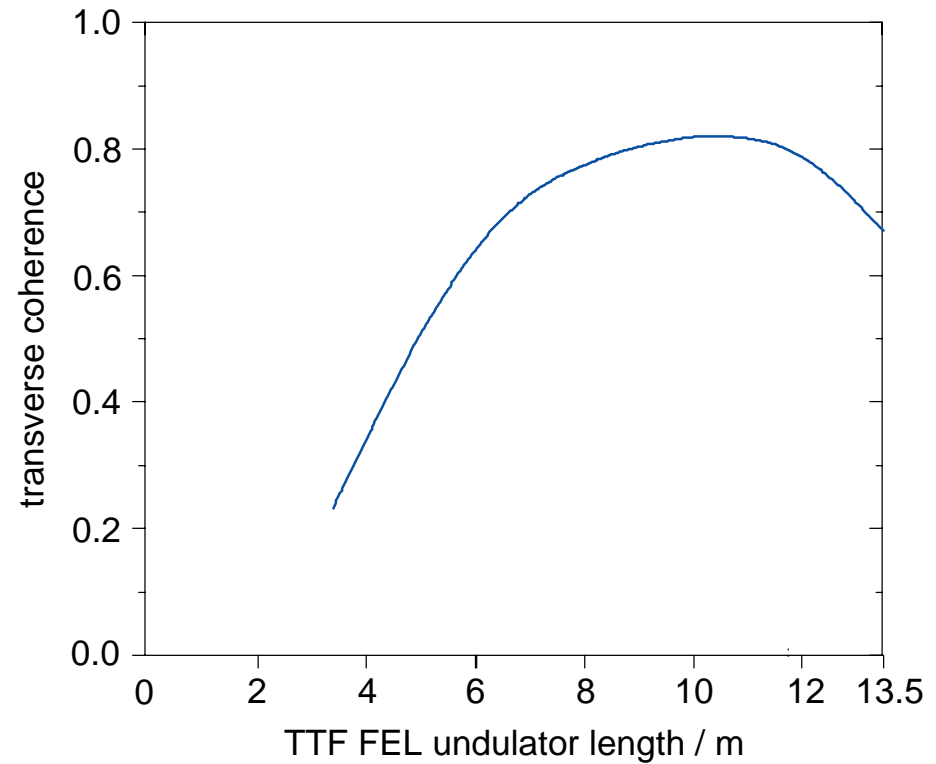

Evolution of the Coherence along the Undulator

- Undulator can be virtually shortened by displacing the beam from the ideal trajectory
- Measurements possible in the last third of the undulator

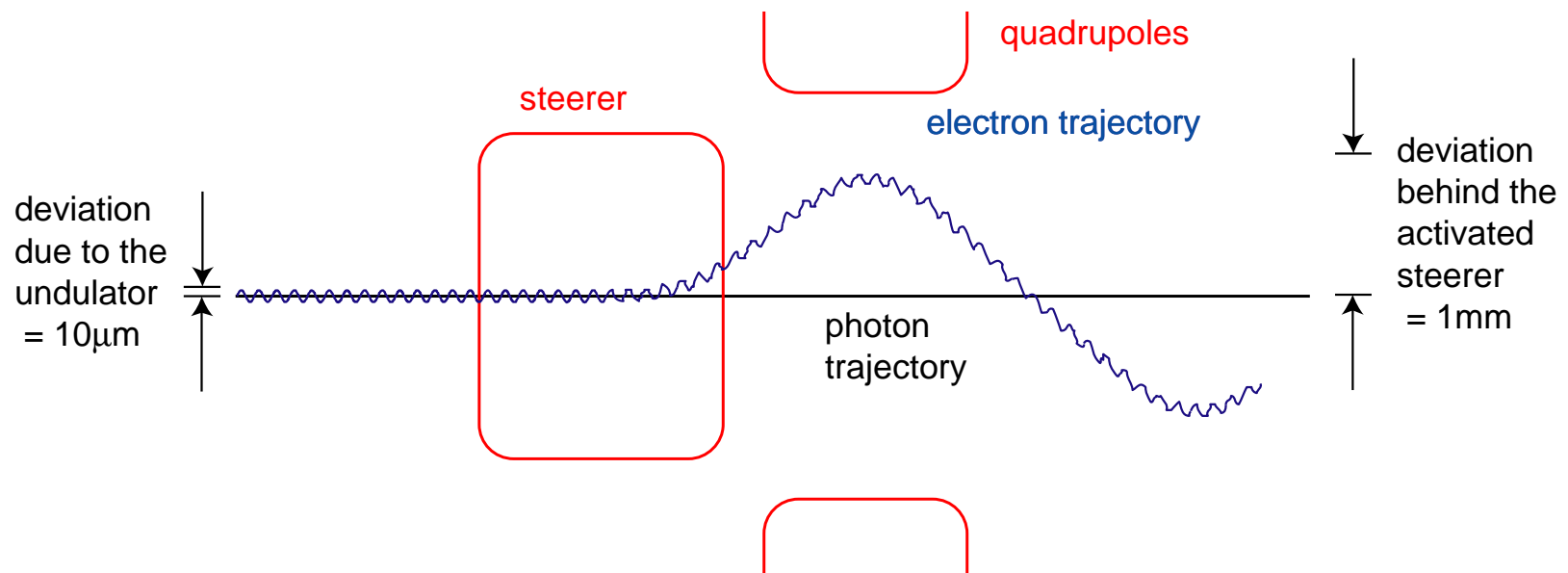

Evolution of the Coherence along the Undulator

Diffraction patterns

Slit separation: 0.5mm

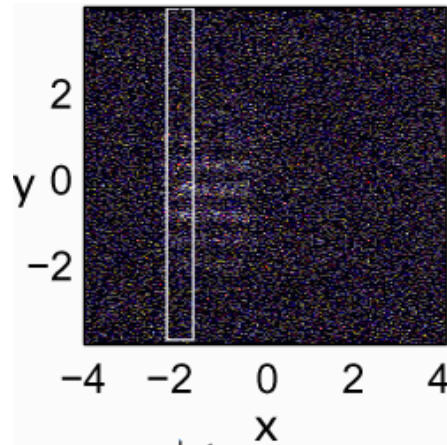

1mm

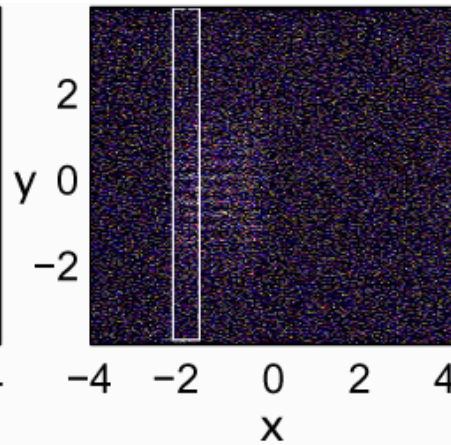

2mm

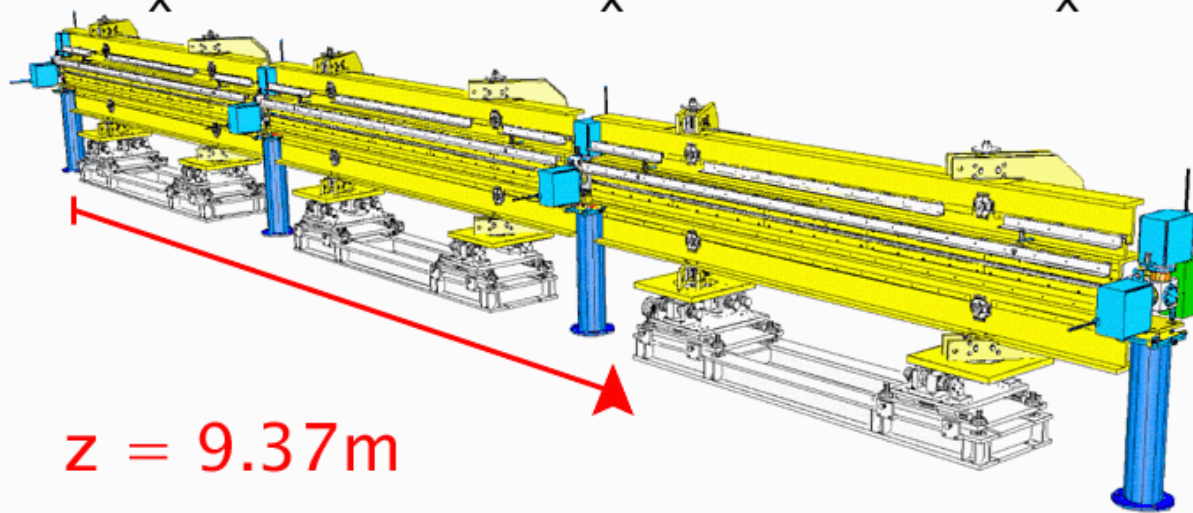
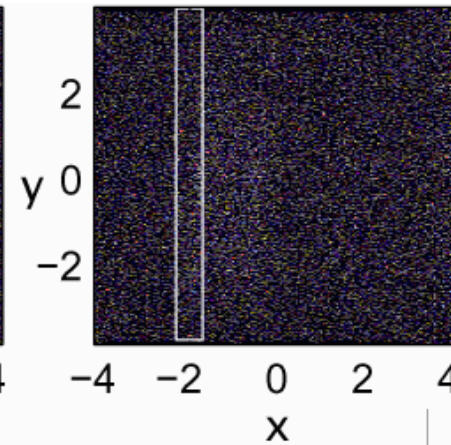

$z = 9.37\text{m}$

Evolution of the Coherence along the Undulator Filtered Projection

Slit separation: 0.5mm

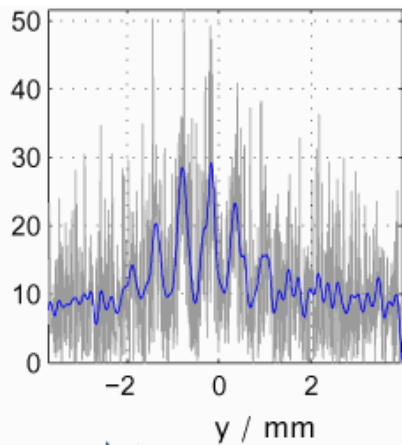

1mm

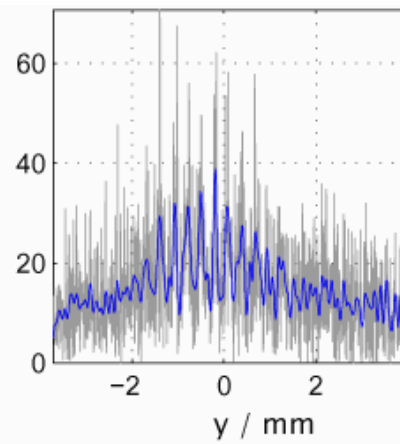

2mm

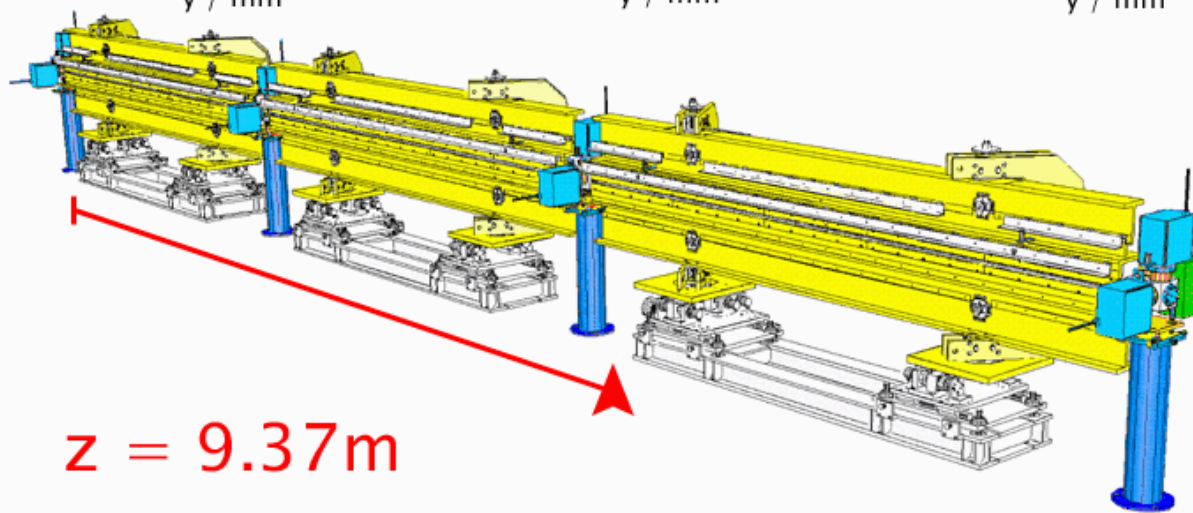
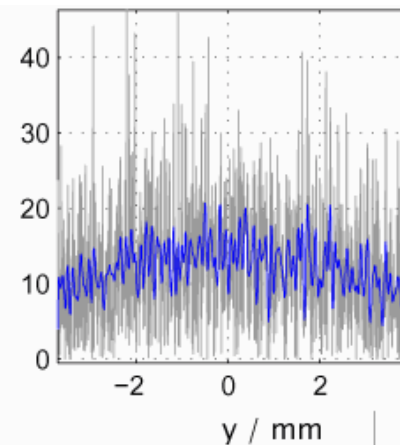

Evolution of the Coherence along the Undulator

Visibility of the Interference Fringes

Slit separation: 0.5mm

1mm

2mm

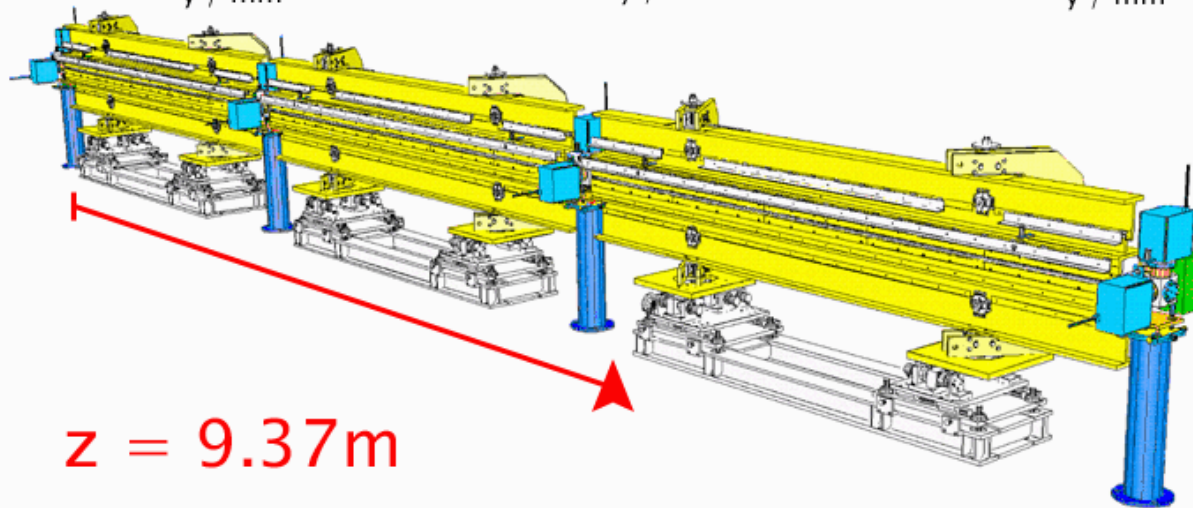
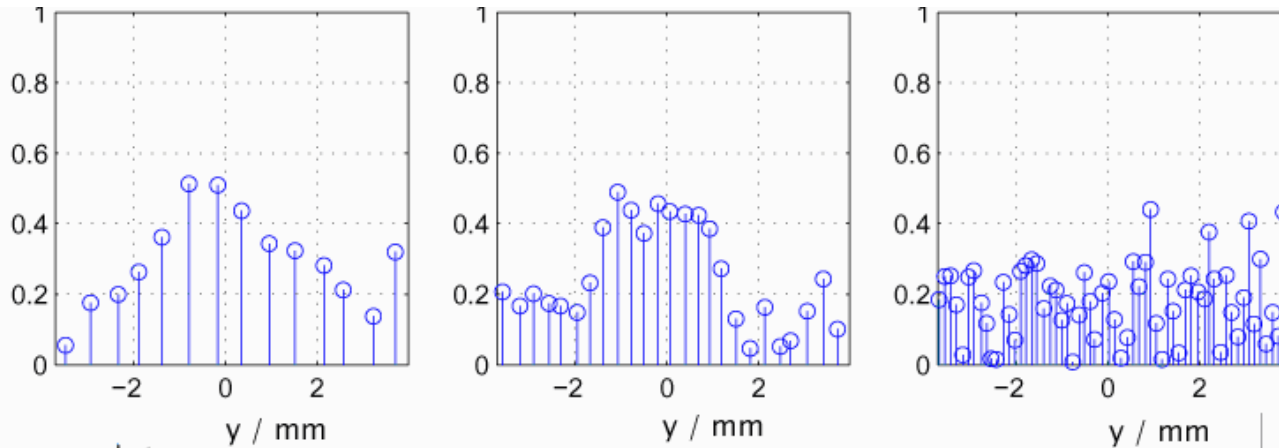

Evolution of the Coherence along the Undulator

Results

Results of the analysis:

- Visibility determined from the maxima and minima of the smoothed projection
- Fit of the near field diffraction pattern to the intensity distributions

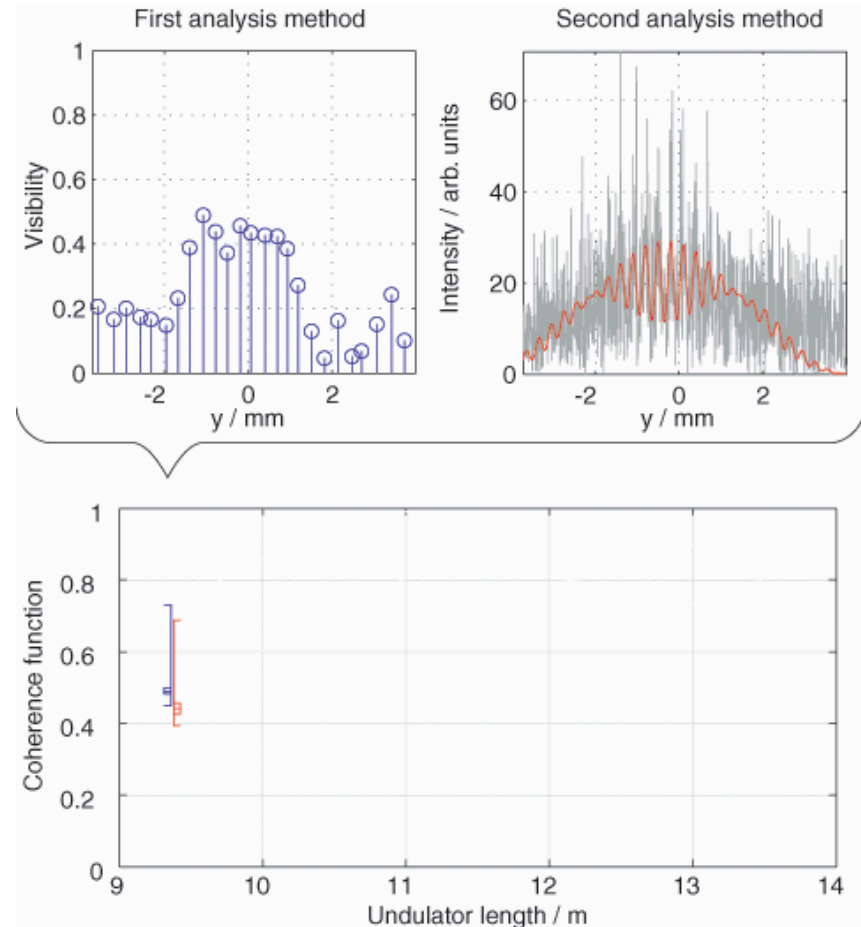

Evolution of the Coherence along the Undulator

Results

- Coherence function for slit separations of 0.5, 1 and 2 mm
- Compare the intensity of the FEL (measured with the MCP detector)

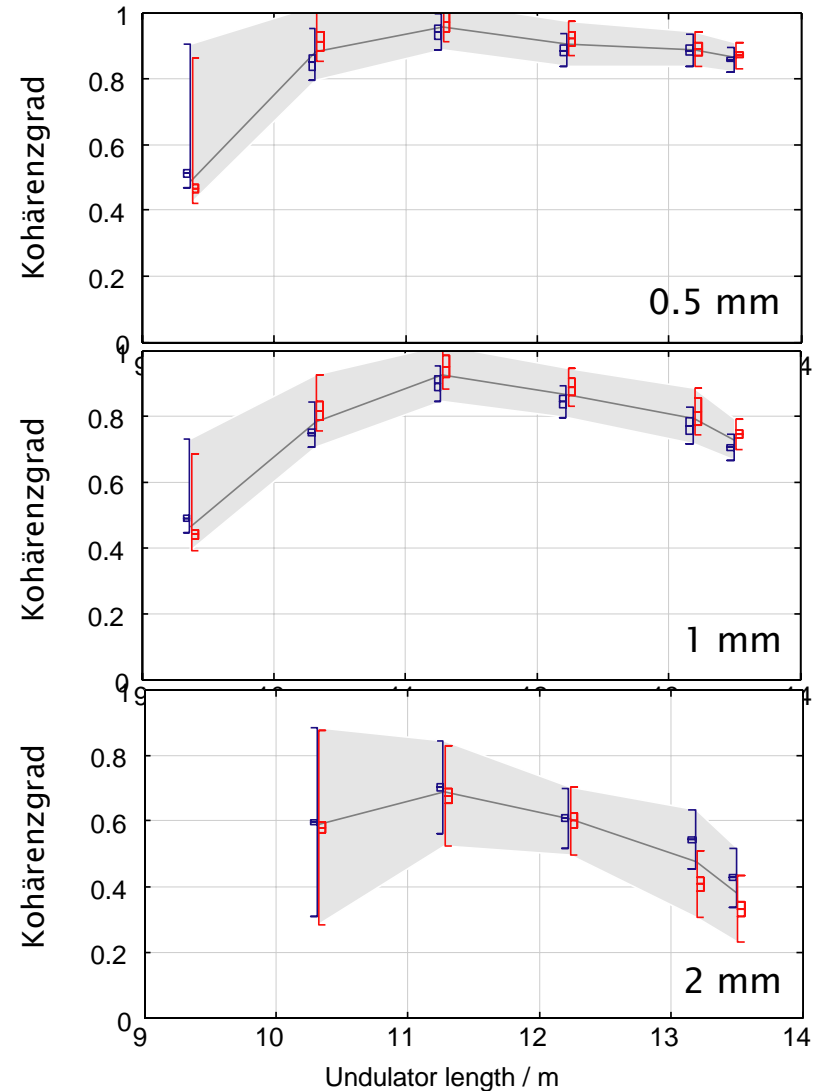
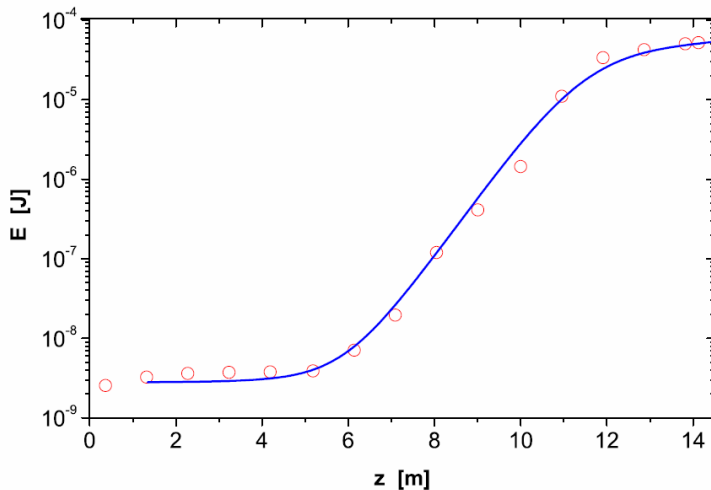

Transverse Coherence of a VUV Free Electron Laser

Summary

- Experimental setup in the ultra high vacuum of the accelerator
- Measurement of diffraction patterns
- Correction of the detrimental effects of the setup
- Evolution of the coherence along the undulator

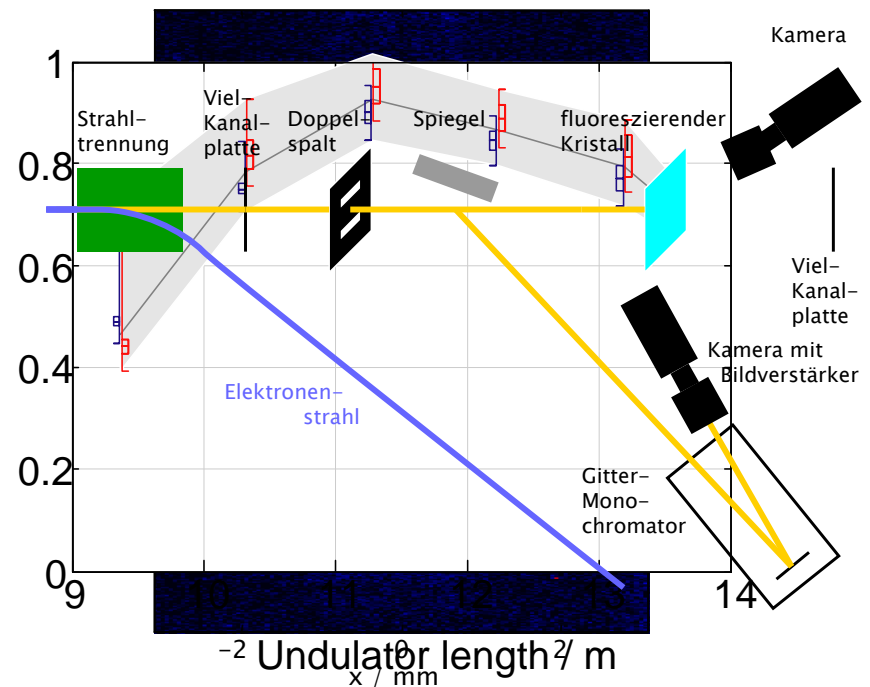

Transverse Coherence of a VUV Free Electron Laser

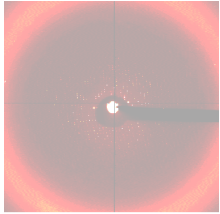

Introduction

- Relevance of Coherence
- Definition and Measurements



Measurements at the TTF FEL

- Challenges for the Measurements
- Experimental Setup

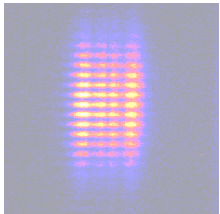

Results

- Coherence as a function of the slit separation
- Development along the undulator

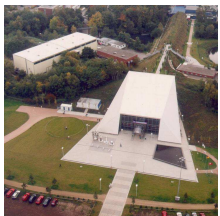

Outlook

- Phase 2 of the TTF FEL

Outlook

TTF Phase 2:

- Extension of the accelerator to a length of 250 m
 - Increase of the electron energy to 1 GeV
- ⇒ FEL wavelengths down to 6 nm



Outlook

- Diffraction patterns
- Challenges:
 - Damage to apertures and detectors

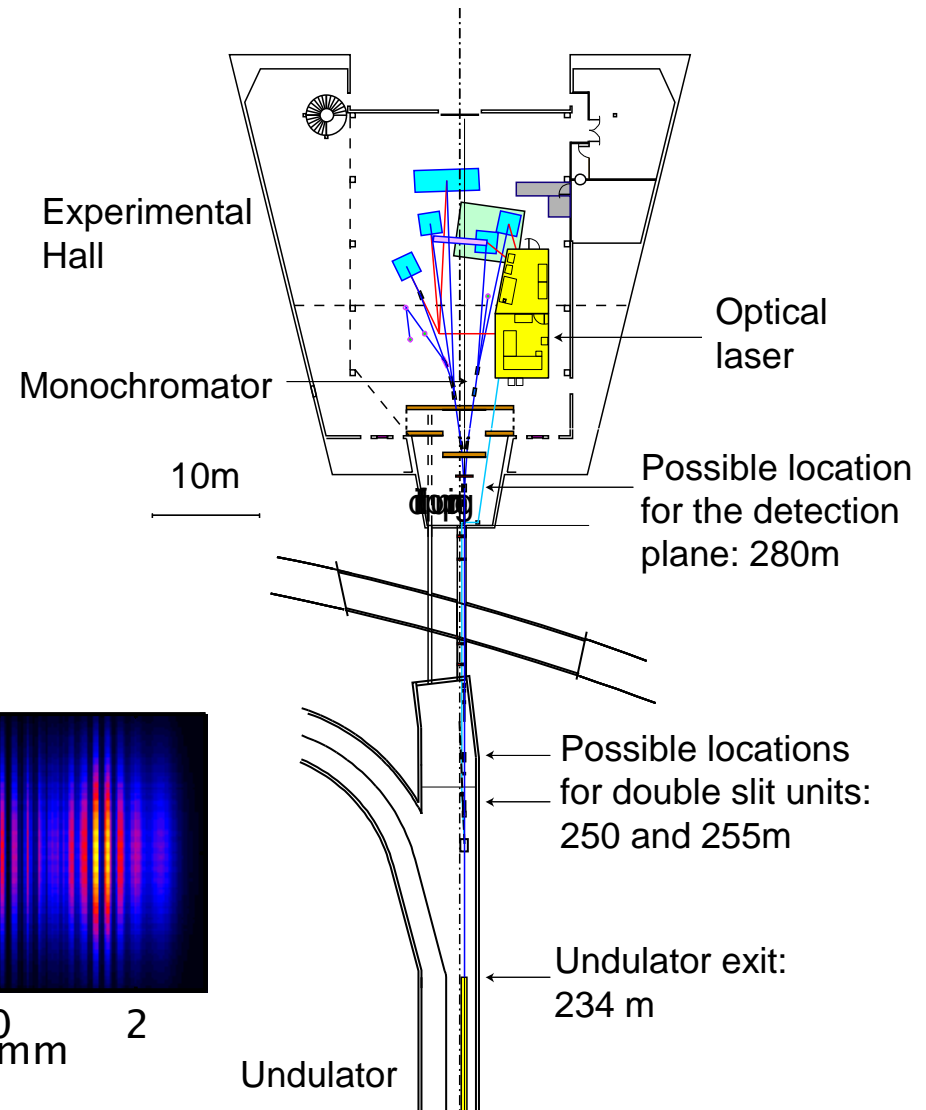
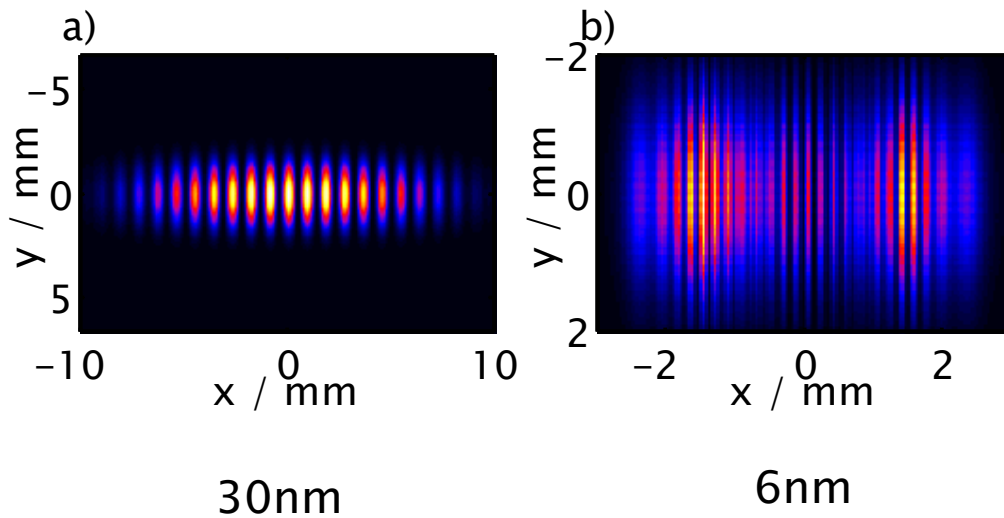

Thank you to the TTF Team!

V. Ayvazyan, N. Baboi, I. Bohnet, R. Brinkmann, M. Castellano, P. Castro, L. Catani, S. Casalbuono, S. Choroba, A. Cianchi, M. Dohlus, H.T. Edwards, B. Faatz, A.A. Fateev, J. Feldhaus, K. Flöttmann, A. Gamp, T. Garvey, H. Genz, Ch. Gerth, V. Gretchko, B. Grigoryan, U. Hahn, C. Hessler, K. Honkavaara, M. Hüning, M. Jablonka, T. Kamps, M. Körfer, M. Krassilnikov, J. Krzywinski, P. Kulinski, C. Lackas, M. Liepe, A. Liero, T. Limberg, H. Loos, M. Luong, C. Magne, J. Menzel, P. Michelato, M. Minty, U.-C. Müller, D. Nölle, A. Novokhatski, C. Pagani, F. Peters, J. Petrowicz, J. Pflüger, P. Piot, L. Plucinski, K. Rehlich, I. Reyzl, A. Richter, J. Rossbach, E. Saldin, W. Sandner, H. Schlarb, G. Schmidt, P. Schmüser, J.R. Schneider, E. Schneidmiller, H.-J. Schreiber, S. Schreiber, D. Sertore, S. Setzer, S. Simrock, R. Sobierajski, B. Sonntag, B. Steffen, B. Steeg, F. Stephan, N. Sturm, K.P. Sytchev, K. Tiedtke, M. Tonutti, R. Treusch, D. Trines, D. Türke, V. Verzilov, R. Wanzenberg, T. Weiland, H. Weise, M. Wendt, T. Wilhein, I. Will, A. Winter, K. Wittenburg, S. Wolff, M. Yurkov, K. Zapfe